



English



profurl.com



Roland Jourdain - We Explore - 2022 Route du Rhum

FURLING SYSTEMS



Profurl new products

NEX^eLite 4.0

Motorized flying sail furler (page 47)



NEX2.5 SWIVEL LOCK (page 56)



PROTECTION COVERS

Design to protect the NEX spools, swivels and swivel locks (page 30)



TACK PLATE

Flying sail furler thimbles for racing boats (page 59)



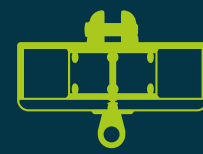

TABLE OF CONTENTS

PROFURL introduction

Manual reefing systems

Structural furlers PRO AM

Flying sail furlers NEX

Top down spinnaker furler SPINEX

Furling system accessories

Motorized furlers NDE2 & NDH2

Motorized flying sails furler: NEX^eLite. 4.0, NEX^e 8.0

Ocean racing: swivel locks, flying sail furlers, stayfurlers

Technical documents

Contact

p 4 - 8

p 9 - 18

p 19 - 22

p 23 - 34

p 35 - 41

p 42

p 43 - 46

p 47 - 52

p 53 - 59

p 60 - 66

p 67



Introduction

THE BEST OF PROFURL FOR ALL OUR CUSTOMERS

In 1980 PROFURL developed its first furling system and then quickly became one of the pioneers of this technology, as well as the worldwide market leader.

Today, thanks to its over 40 years of experience in the reefing-furling market, PROFURL is still considered as one of the major market players.

Whatever your sailing program is (cruising, racing, off shore), and depending on the size of your boat or your budget, you will always find the appropriate PROFURL product to equip your yacht.

Our motto: Deliver the best of PROFURL technology to all our customers.



X-Plore expeditions - Profurl in the extreme South
Profurl products are designed and manufactured to work for you, no matter where you want to sail. Perfect for all your needs, from the toughest to the smoothest sailing!

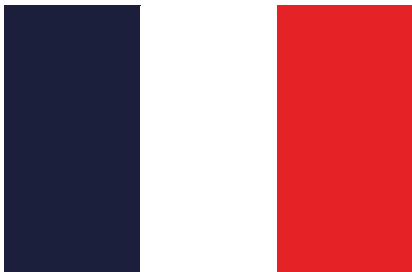

PROFURL:

a comprehensive range of products

PROFURL systems are adapted to any kind of sailing program; off shore races, single handed races around the world, cruising...

- > Manual headsail reefing-furling systems for cruising and racing.
- > Motorized headsail systems for big boats.
- > MK4 in-boom furler: for 15 to 18m boats
- > Flying sails furlers for racing and cruising
- > Stayfurlers for racing and fast cruising



PROFURL: a Wichard Group brand

Made in France: Profurl reefing systems are made in France, guaranteeing quality and peace of mind

The Wichard Group, a world famous French marine hardware manufacturer, took over PROFURL in 2002.

Wichard: specializes in marine hardware: blocks, stainless steel products, tiller extensions...

Product development

R&D: A high involvement

- > Our products are first developed by the R&D department based in Pornichet on the West coast of France. The systems are developed by a team of highly skilled engineers, assisted by the latest computer tools and software.
- > PROFURL products are the result of a tight collaboration between the R&D team and the world's riggers, sail makers and sailors.
- > Each part is submitted to a range of scientific tests in order to test their resistance, beyond what could actually be experienced on a yacht

A rigorous manufacturing process

- > The raw materials are carefully selected and are part of high level specifications, which are planned for extensive use of the systems.
- > The mechanical parts are machined using a controlled patented process, and using extrusions of the purest metallurgical quality. PROFURL systems are not manufactured from castings which can contain impurities causing inherent weaknesses.
- > Each part is micro-balled for a perfect surface finish and then anodised in a special green-gold process in order to assure the best protection against harsh marine environment.

Tests at sea

- > Each new product is submitted to the sea in the most extreme conditions.
- > The systems are also tested by marine industry professionals including some of the world's greatest skippers, sailmakers...

The reasons to choose a PROFURL system

- > A comprehensive range of products meeting your needs.
- > Reliable and performant systems.
- > No maintenance required.
- > A warranty on each product (e.g: 10 year warranty for the manual furling systems).
- > A complete traceability process for a better quality.
- > A professional and efficient assistance.
- > A global network of distributors.
- > Over 30 years of experience in the field.
- > Made in France



Traceability process: each Profurl product is identified by a serial number.

Satisfying our customers first



HIGH QUALITY OF PRODUCTS AND TRACEABILITY

Each system has a serial number engraved in order to trace our products throughout the unit life.

WARRANTY

Each PROFURL product benefits from a world wide warranty: e.g. 10 year warranty for the manual headsail furlers.

ASSISTANCE

Our hotline is available to answer all your questions: product choice, special fitting...

A GLOBAL NETWORK OF DISTRIBUTORS

PROFURL products are distributed in more than 50 countries all over the world through a network of professionals well qualified and regularly trained.

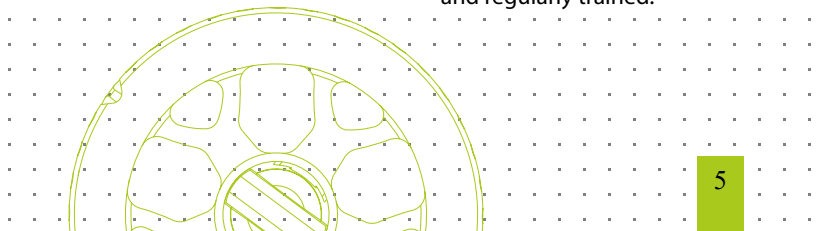

PROFURL PRODUCT OVERVIEW

CRUISING BOATS

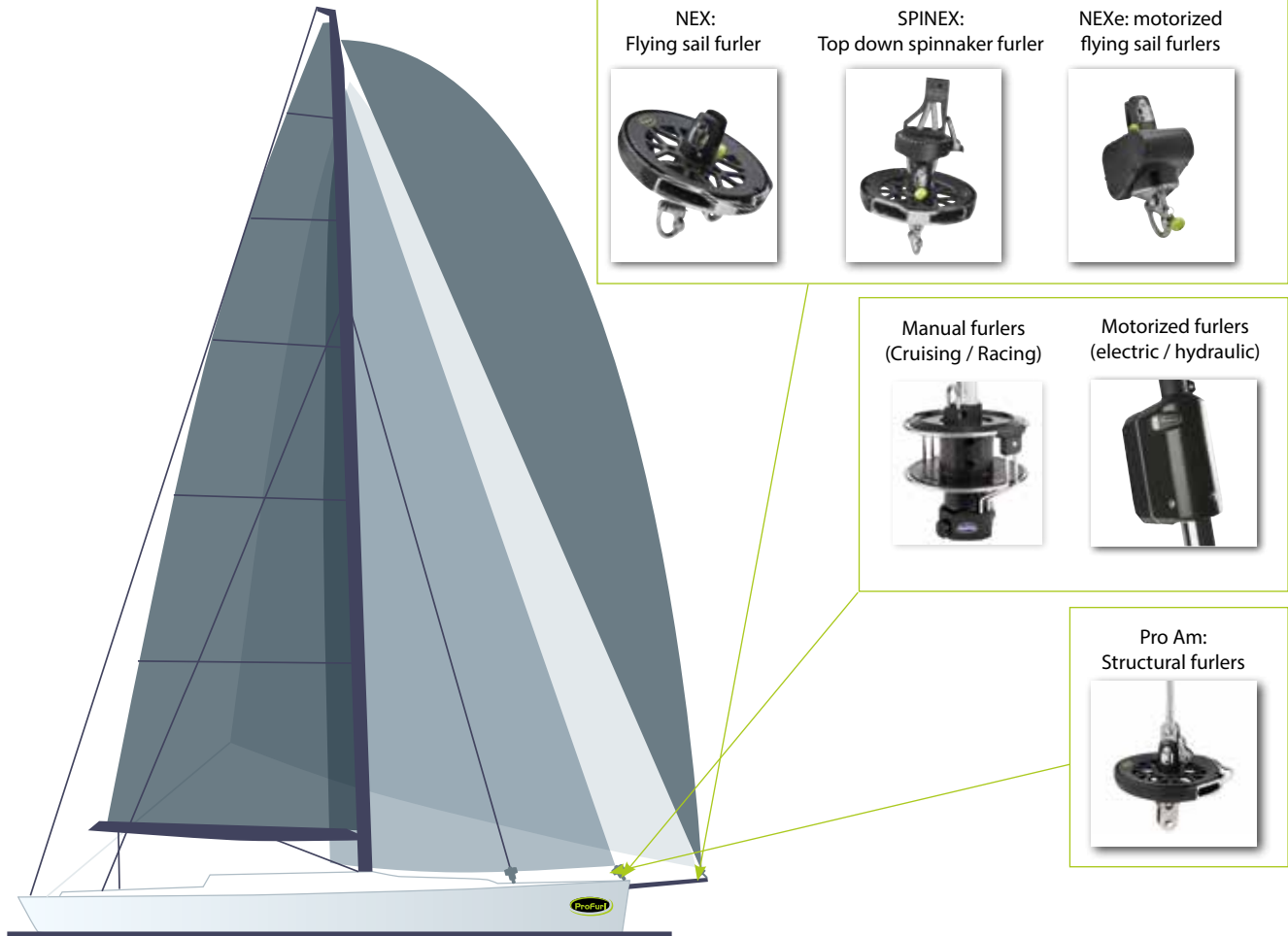

	Structural system (acts as a forestay for the mast)	Sails which can be used with this system	Partial furling of the sail	Possibility to sail with a sail fully deployed	Possibility to drop the sails	Sailing programs
Manual reefing systems	No	<ul style="list-style-type: none"> • Genoa • Staysail • Solent jib 	Yes	Yes	Yes	<ul style="list-style-type: none"> • Cruising • Ocean racing • Long distance cruising
Structural furlers PRO AM	Yes	<ul style="list-style-type: none"> • Genoa • Solent jib 	No	Yes	Yes	<ul style="list-style-type: none"> • Regatta / one design • Day boat
Motorized reefing systems	No	<ul style="list-style-type: none"> • Genoa • Staysail • Solent jib 	Yes	Yes	Yes	<ul style="list-style-type: none"> • Cruising • Long distance cruising
Flying sail furlers NEX NEX ^e	No	<ul style="list-style-type: none"> • Gennaker • Code zero • Staysail • Solent jib • etc... 	No	Yes	Yes	<ul style="list-style-type: none"> • Ocean racing • Offshore racing • Regatta • Cruising • Long distance cruising
Top down furler SPINEX	No	<ul style="list-style-type: none"> • Asymmetric spinnaker 	No	Yes	Yes	<ul style="list-style-type: none"> • Cruising • Long distance cruising

RACING BOATS

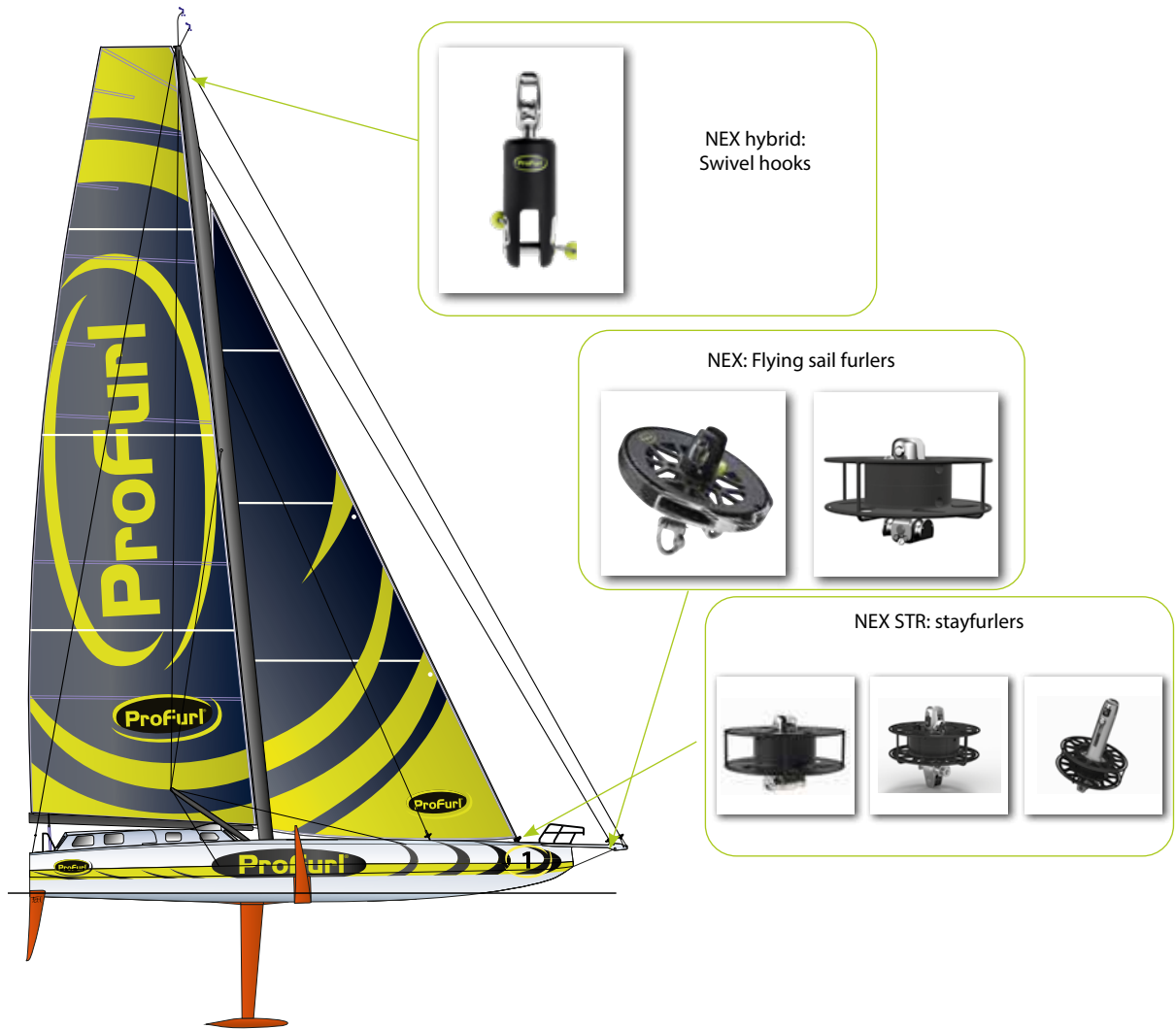

	Structural system (acts as a forestay for the mast)	Sails which can be used with this system	Partial furling of the sail	Possibility to sail with a sail fully deployed	Possibility to drop the sails	Sailing programs
Flying sail furlers NEX HYBRID Swivel Hooks NEX HYBRID	No	<ul style="list-style-type: none"> • Gennaker • Code zero • Sails with hooks 	No	Yes	Yes	<ul style="list-style-type: none"> • Ocean racing • Maxi-yachts
Flying sail furlers NEX	No	<ul style="list-style-type: none"> • Gennaker • Code zero • Staysail • Solent jib• etc... 	No	Yes	Yes	<ul style="list-style-type: none"> • Ocean racing • Offshore racing • Regatta • Cruising • Long distance cruising
Stayfurlers NEX STR	Yes	<ul style="list-style-type: none"> • Genoa • Staysail • Solent jib 	No	Yes	No	<ul style="list-style-type: none"> • Ocean racing • Offshore racing • Regatta / one design • Day boat

Introduction



Bureau Vallée 3 - IMOCA



Class 40 - Crédit Mutuel



IMOCA 60 equipped with Profurl

Profurl: a major player in ocean racing

Since the 1980s Profurl has been an integral part of regattas and offshore racing history. Boc Challenge, Vendée Globe, Route du Rhum, circumnavigation records, mini transat and more recently the America's Cup... Profurl has stood shoulder to shoulder with skippers and equipped all kinds of racing boats from mini 6.50 to 40 m maxi trimarans.

Our unequalled references

- > 2005: World record of Francis Joyon on the multihull Idec (72 days).
- > 2006: Transpacific record on Geronimo with Olivier de Kersauzon.
- > 2006: 1st rank Route du Rhum - Roland Jourdain on Sill & Véoïa (Open 60')
- > 2008: Round the world, non stop, singlehanded record - François Joyon on Idec
- > 2010: Route du Rhum: 1st rank: Groupama 3 multihull
- > 2012: 24H solo record: F Joyon / Idec
- > 2013: Single-handed North Atlantic Record: F Joyon / IDEC
- > 2014: Route du Rhum: 1st rank: Banque Populaire 7
2nd rank: Spindrift 2
- > 2015: Transat Jacques Vabre:
1st rank: Vincent Riou on PRB
2nd rank: Armel Le Cléac'h on Banque Populaire 8
- > 2016 / 2017:
 - > Victory in the Vendée Globe Race
 - > The Jules Verne Trophy: the IDEC Maxi Trimaran – F Joyon, breaking the record in 40 days
- > 2018: Route du Rhum
1st rank: Francis Joyon / Idec Sport
- > 2019: Transat Jacques Vabre:
Class 40: 1st rank: Crédit Mutuel - Lipinski
IMOCA: 2nd rank: PRB - Escoffier
- > 2020/2021: **Victory at the Vendée Globe: Yannick Bestaven on Maitre Coq**
- > 2022: **Route du Rhum**
Ultim: 1st rank
IMOCA: 1st rank
Class 40: 1st rank



**MANUAL REEFING SYSTEMS
CRUISING, RACING &
BELOW THE DECK MODELS**

Manual reefing systems



THE STANDARD-BEARER FOR MANUAL FURLING SYSTEMS

Since the 1980's, Profurl manual furling systems have been designed according to two core principles:

RELIABILITY AND SAFETY

Whatever you're doing at sea, Profurl furling systems ensure smooth sailing under any conditions.

Do you need a furler that can handle severe weather and heavy loads? Thanks to their specially designed mechanisms, Profurl furling systems are the only systems on the market to offer truly reliable furling under severe loads ensuring your safety.

Are you looking for reliability? Profurl furling systems are designed to cover tens of thousands of miles without any specific maintenance. To prove their reliability, a ten-year international guarantee is provided with every model.

Maybe you're in search of extra performance? The weight of the Profurl system has been trimmed down to the minimum. Our Racing range will also improve your craft's overall performance.



Why choose a Profurl furling system?

- > A wide range of PROFURL furling systems for **all sailing applications**.
- > The bearings are maintained in a waterproof grease bath and require **zero maintenance**.
- > **Cruising models** for boats from 5 to 26m, with colourless anodised round reefing foils.
- > **Regatta models** for boats from 6 to 20m, with black anodised oval reefing foils.
- > **A wide range of installation options** to adapt to the deck of your craft
- > Minimised weight.
- > **Guaranteed longevity with corrosion protection** (anodization, insulation)
- > **An international 10-year guarantee.**

A brand-new design that's better for the environment



Profurl furling systems have recently received a design upgrade, abandoning their traditional green anodization for black. This new treatment provides the same level of corrosion protection. It's also better for the environment.

Two ranges of headsail manual furlers

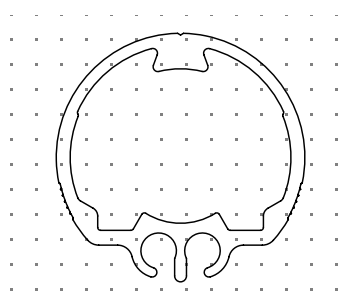

CRUISING SYSTEMS

With 9 models, the Cruising range offers robustness and safety. They are dedicated to boats from 5 to 26 m. They integrate innovations like the double cage arms and the new feeder design. The Cruising models are equipped with silver anodised extrusions.

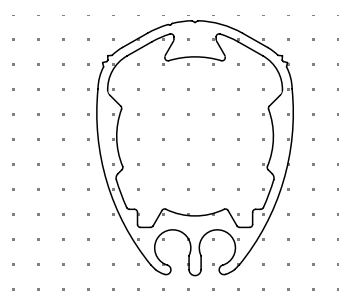

RACING SYSTEMS

The Racing systems bring performance and ease of use thanks to innovations like the opening pre-feeder delivered as standard. They are dedicated to boats from 6 to 20 m and have been especially designed for the racing-cruising sailors. They are equipped with black aerofoil extrusions.

Manual reefing systems

System components

Swivel:

- Ball bearings sealed in a grease bath.
- Two watertight double lips seals to prevent foreign bodies from entering (water, salt, dust...).

Extrusions:

- Aluminium extrusions (Cruising: round silver anodised / Racing: aerofoil black anodised).
- Light weight specialised alloy.
- Optimum torque resistance.

Drum mechanism:

- Withstands tremendous impact.
- Double cage arms prevent the furling line from jumping off the drum.
- Removable: the headsail can be hoisted and set as per a racing foil.
- The drum mechanism contains a maintenance free ball bearings system.

Wrapstop:

Fixed at the top of the stay, it radically prevents the halyard from wrapping around the stay, and reduces potential halyard chafe.

Feeder (except C290):

- Stainless steel (316L).
- No fitting tool, attachment is made with a Velcro webbing.
- Option: opening pre-feeder from Wichard.

Locking devices:

- Standard ones for Cruising and Racing models with short link plates
- Stainless steel locking devices with insulated bushes (recommended for boats with high/intensive use). Also mandatory in case of closed to deck fitting.
- The locking devices are available for standard, medium and long link plates attachment configurations.



Profurl furling systems: the last word in reliability and longevity

Only Profurl technology offers optimal reliability and longevity. Profurl mechanisms are designed to use special bearings which can furl sails under any conditions.

They are fully waterproof, protecting them from corrosion and contamination for maximum longevity.





High performance systems...

- > The extrusions are made lighter and stronger thanks to a special alloy (6106).
- > The ball bearings have an optimized weight / resistance ratio.
- > The Wichard opening pre-feeder is delivered as standard on Racing models to hoist the sail faster.



...reliable and maintenance free

- > The ball bearings are made of high strength 100 C6 carbon steel and are sealed in a grease bath to increase their working load and prevent corrosion.
- > Watertightness is achieved by the use of two double lip seals preventing foreign bodies (salt, sand, dust, water) from entering the bearing mechanism.
- > The not deformable plastic drums withstand impact (e.g. anchor bump, collision) and are resistant to UV.



Ease of use

PROFURL manual furling systems have been designed to ease operations:

- > The standard feeder enables to easily hoist the sail by only one crew member.
- > The optional opening pre-feeder, manufactured by Wichard, smoothly guides the sail's luff tape into the extrusions, whilst rapidly hoisting the sail. When re-hoisting it, the pre-feeder can be reattached to the luff tape without removing the headsail from the extrusion.



Safety of use

- > Double cage arms (exclusive to PROFURL) prevent the furling line from jumping off the drum and allow the furling line to re-align onto the drum by simply pulling on the line.
- > Stainless steel locking devices are dedicated to boats with a closed to deck fitting.
- > On the C480, C520, C530 and R480 models, special locking devices have been designed to withstand the higher loads.



Reliability of materials

PROFURL rigorously selects the materials to be used for the manufacturing of the different components: these parts are submitted to bench-tests in order to assess their resistance.

- > Ball bearings are made of high strength 100 C6 carbon steel.
- > Drums are made of high impact plastic.
- > Extrusions use a special alloy (6106) and offer one of the best weight / resistance ratios.
- > The feeder and the opening pre-feeder are made of stainless steel (316L), except for C290.

Manual reefing systems

DECK ATTACHMENT CONFIGURATIONS

PROFURL furling systems can be adapted to your boat's configuration, not vice versa. PROFURL offers a wide range of fittings, a description of each fitting configuration is listed below:



Long link plates fitting



Standard fitting with short link plates

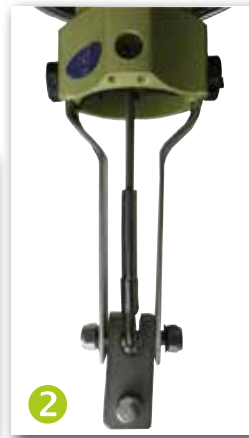

Long link plates fitting



Close to the deck fitting with stainless steel lockers



Fitting with turnbuckle cylinder

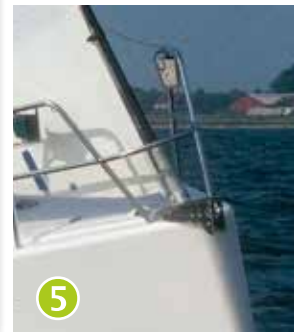

Below the deck fitting

What kind of fitting for my furling system?

1

STANDARD FITTING WITH SHORT LINK PLATES

Type of locking devices: standard and threaded pin for a stay eye fitting

- ⊕ Raise the drum mechanism in order to clear the deck in case of obstacles (bow roller etc.).
- ⊕ Fitting with adjustment plates is also possible

2

FITTING WITH LONG LINK PLATES

Type of locking devices: standard

- ⊕ The drum can be lifted to avoid interference with the anchor and to reduce the sail chafe on the lifelines.
- ⊕ The forestay length is still adjustable.

3

FITTING CLOSE TO THE DECK

Type of locking devices: stainless steel and smooth pin

- ⊕ Increase the luff length

4

FITTING WITH A TURNBUCKLE CYLINDER

The rigging screw goes into the turnbuckle cylinder.

- ⊕ The furler can be fitted lower to the deck.
- ⊕ It is also possible to use a combination of a turnbuckle cylinder and long link plates.

5

BELOW THE DECK FITTING

- ⊕ An aesthetic solution chosen by some boatbuilders (Bénéteau, X-Yacht). Please contact us for more information.
- ⊕ Adjustable tack fitting

C260: THE FURLING SYSTEMS FOR LIGHT BOATS

Especially designed for boats from 5 to 7 m, the C260 model is a self-contained halyard furling system. Cost-effective, easy to install on the existing forestay, the C260 does not require any maintenance.

> The self-contained halyard system

On light sail boats - especially fractionally rigged - it is usually difficult to obtain a tight forestay. The C260 with its self-contained halyard helps to minimise forestay sag by reducing mast compression created by a combination of loads from the halyard and sail.

> Ease of installation

The C260 does not require a specialised attachment to the forestay stem head, it is simply attached to the lower swage terminal of the forestay (eye and holes plates or turnbuckle).

For boats transported and stored on a trailer, the C260 can be separated in two sections reducing the risk of damage while in transit.

> Ease of use

The self-contained halyard passes over a sheave box fitted into the top of the extrusion and returns down to a sheave and cam cleat. Once the sail is hoisted and tensioned, the remaining length of the halyard is used as a furling line.



Manual reefing systems



CRUISING MODELS

- > Large range of 10 models for boats from 5 to 26 m.
 - > Round and silver anodised profile.
 - > Several fitting possibilities: adjustment plates, long link plates, turnbuckle cylinder, below the deck fitting, stainless steel locking devices
 - > Additional option: opening pre-feeder, stainless steel locking devices
 - > 10 year world wide limited warranty.
 - > **New:** the C290, C320, C350, C420 and C520 models can hold an increased forestay diameter.
- For example: for an 8mm forestay, you can choose a C320 instead of a C350. If using a swageless eye, you must take both the maximum sail surface area and the drum capacity into consideration.

How to choose my furling system?

To correctly select your own furling system, refer to the following steps:

- Step 1: Define your sailing program: cruising or racing-cruising.
- Step 2: Measure accurately the diameter of the forestay (see table below).
- Step 3: Choose one of the fitting systems described on page 14.

		Boat length (meter) & max sail area										
Model	max forestay Ø mm	5 - 7	7 - 9	9.50	10	11	12	13	14	16	18	26+
C260	5	15M ²										
C290	6.35 / 7*		30M ²									
C320	7 / 8*			40M ²								
C350	8 / 10*					55M ²						
C420	10 / 12.7*							80M ²				
C430	12.7								100M ²			
C480	14.3									120M ²		
C520	16 / 19*										140M ²	
C530	19											220M ²

Cruising range	C260	C290	C320	C350	C420	C430	C480	C520	C530
	Self-contained halyard	Halyard swivel systems							
Max forestay Ø (mm)	5	6,35 / 7*	7 / 8*	8 / 10*	10/12.7*	12,7	14,3	16 / 19*	19
Equivalent in # rod	-	# 10	# 12	# 17	# 22	# 40	# 48	# 60	# 76
Clevis pin Ø (mm)	-	8-10-12-14-16	10-12-14-16-19-22-25	16-18-19-22-25-28					
Furling standard length (m)	8,50	8	10	12	16	18	18	20	22
Extrusion length (m)		2							
Weight / meter (Kg)	0,408	0,557	0,661	0,728	0,933	0,933	1,200	1,460	1,460
Removable drum	No	No				Yes			
Feeder	No	No				Yes			
Double luff groove	Yes	No				Yes			
Luff line Ø (mm)	6			5				6	
Luff rope pre-feeder	No					Option			
Long link plates	No					Option			
Turnbuckle cylinder	No	Yes				Option			
Stainless steel locking devices	No	Option: all models but C430 model - Specific locking devices: C480, C520, C530							
Warranty		10 year world wide warranty							

*If using a swageless eye, you must take both the maximum sail surface area and the drum capacity into consideration.

RACING MODELS

- > Range of 5 models for boats from 6 to 20 m.
- > Black anodised aerofoil profile.
- > Several fittings: adjustment plates, long link plates, turnbuckle cylinder, below the deck fitting, stainless steel locking devices
- > Options: stainless steel locking devices, turnbuckle cylinder
- > 10 year world wide limited warranty.

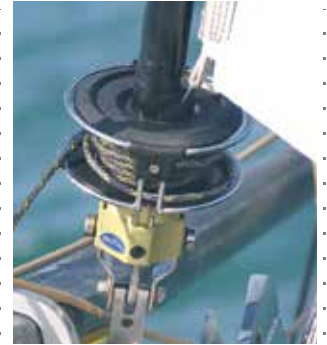

How to choose my furling system?

To correctly select your own furling system, refer to the following steps:

- Step 1: Define your sailing program: cruising or racing-cruising.
- Step 2: Measure accurately the diameter of the forestay (see table below).
- Step 3: Choose one of the fitting systems described on page 14.

		Boat length (meter) & max sail area										
Model	Max forestay Ø mm	6	7	8	9	10	11	12	13	14	16	19
R250	6.35	30M ²										
R350	8				45M ²							
R420	10						70M ²					
R430	11.1							90M ²				
R480	12.7 / 14*										100M ²	

Racing range	R250	R350	R420	R430	R480
	Halyard swivel systems				
Max. forestay Ø (mm)	6,35	8	10	11.1	12.7 / 14*
Equivalent in # rod	# 10	# 17	# 22	# 30	# 40
Clevis pin Ø (mm)	8-10-12-14-16		10-12-14-16-19-22-25		16-18-19-22-25-28
Furling standard length (m)	8	12	14	16	18
Extrusion length (m)	2	2	2	2	2
Weight / meter Kg	0,383	0,638	0,835	0,835	1,200
Removable drum			Yes		
Feeder			Yes		
Opening pre-feeder			Yes		
Double luff groove			Yes		
Luff line Ø (mm)	5 mm				6 mm
Long link plates			Option		
Turnbuckle cylinder			Option		
Stainless steel locking devices	Option for all models but R430 model - For R480 specific locking devices				
Warranty	10 year world wide warranty				

*If using a swageless eye, you must take both the maximum sail surface area and the drum capacity into consideration.

THE SPECIAL R250 FOR J80:

The R250 is the official furling system for the J80 class.

It is available as a complete version or as a kit (to be mounted on Harken extrusions).

The specific swivel system uses ceramic bearings, allowing you to furl the genoa even faster.



Manual reefing systems



BELOW THE DECK MODELS

- > For Cruising models from C290 to C430 and Racing models from R250 to R480
- > Adjustable tack point above the deck
- > Aesthetic solution enabling easier operations with anchor
- > Optimized luff and thus better boat performances
- > 10 year world wide warranty



© photo X Yachts

Below the deck fitting	C290	C320SP	C350SP	C420SP	C430SP	R250SP	R350SP	R420SP	R430SP	R480SP
Model	Cruising model - round & silver profil					Racing model - oval & black profil				
Max sail area	30 m ²	40 m ²	55 m ²	80 m ²	100 m ²	30 m ²	45 m ²	70 m ²	90 m ²	100 m ²
Max. forestay Ø (mm)	6,35	7	8	10	12,7	6,35	8	10	11,1	12
Equivalent in # rod	# 10	# 12	# 17	# 22	# 40	# 10	# 17	# 22	# 30	# 40
Clevis pin Ø (mm)	8/10/12/14/16		10/12/14/16/19/22/25			8/10/12/14/16		10/12/14/16/19/22/25		16/19/22 / 25/28
Furling standard length (m)	10	12	14	16	18	8	12	14	16	18
Extrusion length (m)	2 m									
Weight / meter Kg	0,557	0,661	0,728	0,933	0,933	0,383	0,638	0,835	0,835	1.200
Removable drum	No									
Feeder	No	Yes								
Opening prefeeder	Option					Yes				
Double luff groove	No	Yes								
Luff line Ø (mm)	5									6
Long link plates	Option									
Turnbuckle cylinder	Yes									
Stainless steel locking devices	Option for all models but C430SP and R430SP models - Specific locking devices for R480 model									
Warranty	10 year world wide warranty									

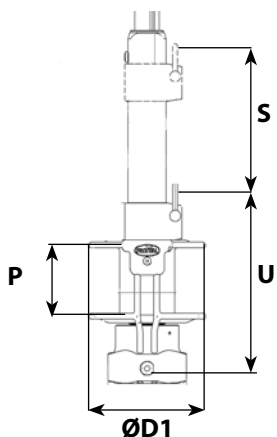

BELOW THE DECK: DIMENSIONS (MM)										
	C290	C320SP	C350SP	C420SP	C430SP	R250SP	R350SP	R420SP	R430SP	R480SP
P	150	190	190	190	190	150	190	190	190	250
S	170	250	300	300	300	170	250	300	300	690
U	213	265	265	265	265	210	265	265	265	342
ØD1	140	192	222	242	242	140	192	242	242	276



PRO AM
STRUCTURAL FURLERS

PRO AM STRUCTURAL FURLERS

PRO AM STRUCTURAL FURLERS

With new spools and new swivels, the PRO AM range is getting bigger and better with the new range of NEX flying sail furlers housing mechanisms. PRO AM is a new generation of structural furlers for 5 to 9.5 metre boats designed for "all or nothing" sailing (with sails fully unfurled). The sail is hoisted and hauled thanks to a second swivel called a "halyard swivel". PRO AM also allows you to strike the sail for wintering, maintenance or just for storage after use.

3 sizes available for 5, 6 and 7 mm diameter stays.

Why choosing PRO AM?

- > The ideal system for Day Boats and Sports Boats
- > Light and easy to handle
- > Sail can be hoisted and lowered
- > Possibility to remove easily the halyard swivel only.
- > Quick fitting and removal for trailer boats
- > Profurl system: maintenance-free components mounted in a sealed grease bath.
- > Three-year Profurl worldwide limited warranty.



What's the difference between PRO AM and a classic furler?

Structural

- > The stay fastens directly on the spool and the swivel, so PRO AM supports the mast.

All or nothing sailing

- > Because it is a structural element, PRO AM allows you to sail with the sail fully unfurled or fully furled. A classic furler with extrusions allows you to sail partially furled.

Efficient

- > The PRO AM halyard swivel is fitted with ball bearings to ensure excellent rotation even under heavy loads.
- > PRO AM has light and compact components (spool and swivel) and textile fastening systems on the halyard swivel. With no extrusions to increase windage, the sail enjoys superior performance.

PRO AM applications

- > Day boats
- > Sports boats
- > One designs and class boats (J80, Surprise, Dragon...)

Sail types

- > Jib, solent mounted on snap hook or sleeve

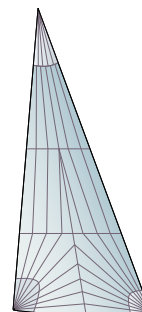

PRO AM: how does it work?

- 1 Unlike a classic furler, the PRO AM has a halyard swivel (or tensioning swivel) which allows you to hoist and lower the sail.
- 2 Attachment of the halyard on the halyard swivel
- 3 The halyard clew of the sail is fastened to the Wichard soft shackle.
- 4 The head swivel allows the cable to rotate and thus furl the sail.
- 5 The tack of the sail is fastened to the Wichard shackle.
- 6 The stay (5, 6 or 7 mm single strand) is fastened to the drum and the swivel at the head
- 7 The stainless steel toggles are fitted to the boat's deck and mast.



Performance

S-GRIP: Better line grip

The special groove design, allowing for deformation of the line, ensures:

- better line grip, even when wet!
- easier furling
- minimum line wear



OPTIMAL FURLING: Furl without effort

The optimal spool diameter provides ideal torque, which:

- makes furling easier
- reduces effort



XTRA-LIGHT SYSTEMS: Lightness first

The size and weight of each component (spool, swivel, and terminals) have been optimised to:

- improve sailing performance
- ensure easier handling of the systems



Safety

SAFE SYSTEM enables you to stop the running of the furling line during deployment of sail and thus:

- prevent accidents or damage caused by a free running line.
- manoeuvre more quickly and easily
- prevent excessive wear of the line

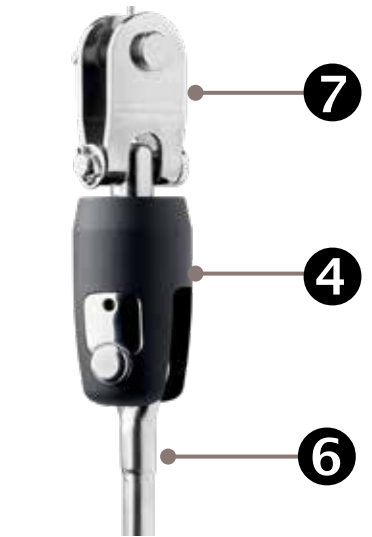

PRO AM

STRUCTURAL FURLERS

CHOOSE YOUR PRO AM FOR BOATS FROM 5 TO 12M:

	PRO AM 1.0	PRO AM 2.0	PRO AM 3.0
Boat length	from 5 to 7 m	from 7 to 9,5 m	from 9 to 12 m
Forestay diameter	5 mm	6 mm	7 mm
System working load*	1000 Kg	1500 Kg	2000 Kg
Halyard swivel working load	600 Kg	600 Kg	600 Kg
Spool diameter	150 mm	150 mm	150 mm
Pin toggle diameter	8 mm	10 mm	12 mm
Pin eye diameter	8 mm	10 mm	12 mm



*: The spool and swivel working loads take into consideration the stainless steel cable breaking loads used as a forestay.

Technical data: ProAm

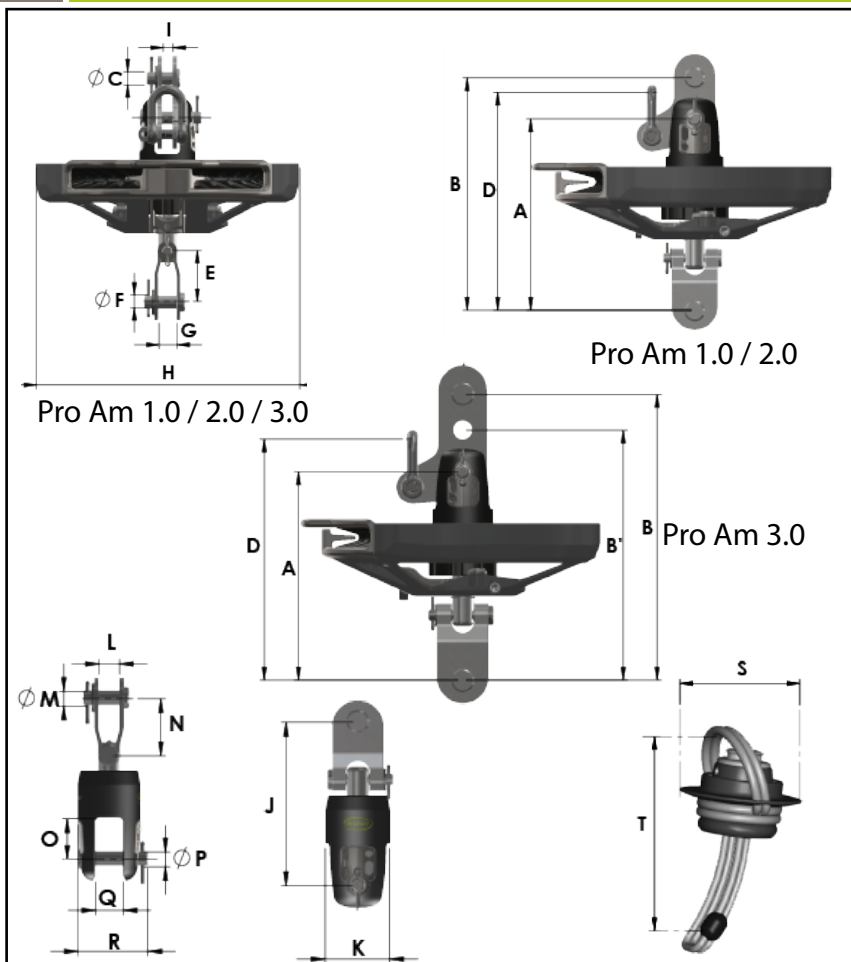

Technical data: spool	PRO AM 1.0	PRO AM 2.0	PRO AM 3.0
A mm	112	136.5	142.5
B / B'	136	166.5	171.5 / 196.5
C mm	8	10	12
D mm	126	156.5	163.5
E mm	31	39,5	45,5
F mm	8	10	12
G mm	11	14	15
H mm	160	160	160
I mm	6	10	10
Ø spool : mm	150	150	150
Ø furling line mm	Ø8	Ø8	Ø8
Weight: spool (only) Kg	0.700	0.960	1,100

Swivel	PRO AM 1.0	PRO AM 2.0	PRO AM 3.0
J mm	87,2	107,8	113,8
K mm	34	42	42
L mm	11	14	15
Ø M mm	8	10	12
N mm	31	39,5	45,5
O mm	22	26	26
Ø P mm	8	10	12
Q mm	15	18	18
R mm	38	46,5	46,5
Swivel weight Kg	0.200	0.390	0.460
Halyard swivel			
L mm	70	70	70
M mm	129	129	129
Halyard swivel weight (only) Kg	0,150	0,150	0.150



NEX

FLYING SAILS FURLER

NEX

Flying sail furlers

NEX, THE NEW GENERATION FURLER

The new version of the Nex furler is now available with many innovations and technological improvements. These innovations, resulting from our expertise gained since the launch of the first version of the NEX in 2010 will bring you even more performance, safety and comfort when sailing.

Its range of 7 models covers all sizes of sails (up to 350m²) and enables it to equip boats of more than 80'.

Why choose a NEX furler?

- **Performance:** Speed of furling, weight and optimized footprint
- **Comfort and safety** during furling/unfurling operations FurlAssist (pawl function), ease of furling
- **Ease of use:** easy installation, fast and intuitive sail trimming
- **Reliable,** proven and maintenance-free technology
- **Wide range of end fittings** for better adaptation to your deck layout
- **Product with modern design**
- **3-year international warranty**



What types of sails?

NEX furlers are intended for flying light wind or heavy sails. Developed in partnership with the largest sailmakers, the NEX furlers allow you to get the best out of your sails while handling them easily and safely

↘ **Light sails:**
Gennaker, Code 0, Screacher, light genoa

↘ **Heavy sails:**
• Solent, stay sail

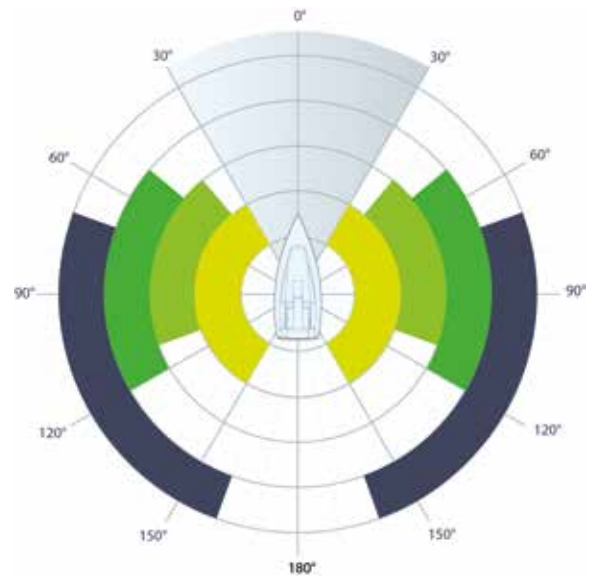
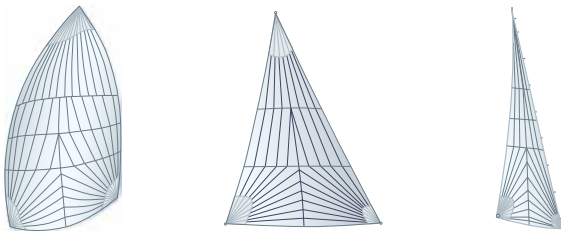

NEX furlers: the reference in the racing world:

Since their launch in 2010, NEX furlers have often been in the lead in offshore races and have been chosen to equip the most efficient yachts:

- IMOCA,
- Class 40,
- Ultim,
- Multi 50,
- M32,
- Mini 6.50
- Etc...

Classe 40 - Inter Invest - Matthieu Perraut



NEX

Flying sail furlers

SAFETY

SAFE SYSTEM : Removable line

Already present on the 1st generation of NEX, the SAFE SYSTEM enables you to stop the furling line running during sail deployment and therefore helps:

- prevent accidents or damage caused by a free running line.
- manoeuvre more quickly and easily
- prevent excessive wear of the line



NEW TERMINALS:

- Swivel eye
- Compact halyard block
- Solid sheave

See pages 30 and 31

PERFORMANCE

OPTIMUM FURLING : Furl quickly and without effort

A real technological improvement, Nex drums are the widest on the market and provide:

- Fast furling speed
- Comfortable furling needing less effort during manoeuvres. A real advantage with small crews



XTRA-LITE SYSTEMS : Continuously striving for lightness

The general design and the choice of materials enable us to offer systems that are ever lighter for:

- Improved performance of the boat
- Ease of use of the systems during manoeuvres



S-GRIP : Better line grip

The specific design of the drum groove provides:

- Better rope grip
- Easier sail furling without skidding
- Limited rope wear



NEW :
Anti-shock housing for
better protection and longer life



EASY TO USE

I-CONNECT : **Quick fit sailing system**

Available on swivel shackle and drum mechanisms, I-Connect offers:

- Quick opening and closing of the pin by pulling on the ball (regardless of the direction of the force)
- Excellent grip (even with gloves)
- A simple new mechanism without jamming - easy to dismantle



QUICK FIT : **Line Fitting**

Already present on the 1st NEX, Quick Fit makes fitting and removing a spliced line quick and easy:

- Quick Installation
- Possibility of splicing to length
- Possibility of leaving the line in position
- Possibility of using the same line for several systems



TUNE & LOCK : **Easy fitting and adjustment**

Installation and adjustment of the housing is made simple with a single screw:

- Precise adjustment of the housing according to the orientation of the line
- Decreases the friction of the line on the housing
- Automatic height adjustment of the housing



INNOVATION!

FURLASSIST: **INTUITIVE AND SAFE ASSISTANCE** **FOR FURLING**

A MAJOR INNOVATION of this new Nex range, the FURLASSIST ratchet function is a real plus for your manoeuvres allowing::

- Better control of furling avoiding accidental unfurling of the sail
- Reliable furling due to the permanent engagement of the pawl
- Safety: it only unlocks when hauling in the line fast
- Simplicity: operates in both directions and without additional line
- Easy installation and removal (2 screws)



NEX

Flying sail furlers

SELECTION TABLE

	NEX 0.9	NEX 1.5	NEX 2.5	NEX 4.0	NEX 6.5	NEX 8.0	NEX 12.0
Light sail area (i.e gennaker)*	35m ²	60 m ²	80 m ²	140 m ²	240 m ²	300 m ²	450 m ²
Stormsail area*		20 m ²	30 m ²	45 m ²	65 m ²		
Option : Ratchet feature FurlAssist	✓	✓	✓	✓	✓	✓	✓
Working Load**	900 Kg	1500 Kg	2500 Kg	4000 Kg	6500 Kg	8000 Kg	12.000 Kg
Spool diameter	120 mm	150 mm	180 mm	220 mm	220 mm	250 mm	250 mm
Standard lower terminal	Clevis pin snap shackle	Clevis pin snap shackle	Clevis pin snap shackle	Clevis pin snap shackle	Trigger snap shackle	-	-
Standard upper terminal	Swivel eye	D shackle	D shackle	D shackle	D shackle	-	-
Examples for a monohull	Mini 6.50 - Cruising boat 27'	Cruising boat 32'	Cruising boat 42'	Cruising boat 50'	Cruising boat 55'	Cruising boat 60'	Cruising boat +65'

List of terminals and options available

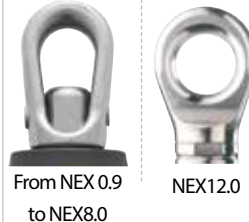

Description	D shackle	Eye	Halyard block	MXEvo: halyard shackle
Benefits	<ul style="list-style-type: none"> • Wichard forged shackle in High resistance stainless steel 	<ul style="list-style-type: none"> • Compact • Prevents the rope wear • Perfect for lashings 	<ul style="list-style-type: none"> • 2/1 halyard • No loop - no twist • Compact • Dismantable • With balls + bearing 	<ul style="list-style-type: none"> • 2/1 halyard • Becket for 3/1 purchase • Heavy load • Compact • Stainless steel • Rope dia: 8 to 14 mm
Upper terminals	As standard on all models but NEX 0.9 - NEX 8.0 - NEX 12.0	<ul style="list-style-type: none"> • As standard: NEX0.9, • Option: all models 	<ul style="list-style-type: none"> • Option for all models (not available for NEX 0.9 & NEX1.5) 	<ul style="list-style-type: none"> • Option for all models (not available for NEX 6.5 - NEX 8.0 - NEX 12.0)
Lower terminals	X	Option: for models up to NEX4.0	<ul style="list-style-type: none"> • Option for all models (not available for NEX 0.9 & NEX1.5) 	<ul style="list-style-type: none"> • Option for all models (not available for NEX 6.5 - NEX 8.0 - NEX 12.0)

*: The values shown in the table are for information only and should be verified by a professional taking into account the characteristics of the boat.







** The working loads shown are the maximum working loads of the mechanisms only and are not the loads of the complete system when terminals are included. The product should not be used above these working loads in any circumstances.

Profurl + points: Proven and unique technology

- Performance even under high loads
- Reliability and longevity of the mechanisms

NEX furlers and manual furlers share the Profurl technology that has created the reputation of the brand: Profurl mechanisms are the only ones to use bearings made from very hard **100C6 carbon steel** which allow furling even under high loads (no crushing of the balls). The mechanism is mounted in a waterproof grease bath and is protected from external aggressions (salt, sand, etc.) and does not require any maintenance.



 <p>Standard version</p>	 <p>Fairlead version</p>	 <p>For NEX 6.5</p>	 <p>For NEX 8.0</p>		
<p>Clevis pin snap shackle</p>		<p>Trigger snap shackle</p>		<p>Solid sheave</p>	<p>Swivel hook</p>
<ul style="list-style-type: none"> • Wichard forged snap shackle • Ergonomic ball for quick opening • Fairlead feature (part # 54106) 		<ul style="list-style-type: none"> • Wichard snap shackle • Quick opening • Compact 		<ul style="list-style-type: none"> • With becket • Quick opening • 3/1 purchase • Stainless steel 	<ul style="list-style-type: none"> • Weight savings • Compact • Ease of installation (no drilling) • Reduce mast compression
<p>X</p>		<p>X</p>		<p>X</p>	<ul style="list-style-type: none"> • Option: NEX 2.5, NEX 4.0, NEX 6.5, NEX 8.0 and NEX 12.0
<ul style="list-style-type: none"> • Standard versions: from NEX 0.9 to NEX4.0 • Fairlead version: NEX 0.9 & NEX1.5 		<ul style="list-style-type: none"> • As standard: NEX 6.5 • Option: NEX 8.0 		<p>Option: from NEX1.5 to NEX12.0</p>	<p>X</p>

NEX

Flying sail furlers

ACCESSORIES

SOFT SNATCH BLOCKS - FOR 2/1 HALYARD

5 models available - Rope size: 10 to 24 mm.
Sheave and cheeks in anodised aluminium



STAINLESS STEEL AND ALUMINIUM THIMBLES

Available in stainless steel or aluminium, their form facilitates the positioning of the sail in the mechanism forks. Their cut-outs allow good positioning of the lashings avoiding excessive wear. Stainless steel thimbles are an economical solution. Aluminium thimbles provide performance and lightness; they are used for racing programmes.



CABLE-FREE THIMBLES

The cable-free thimbles aim at being installed on sails without furling cable. Their specific design enables the optimized furling and easy fitting of the webbings. Available in 3 sizes for NEX2.5, 4.0, 6.5 and 8.0

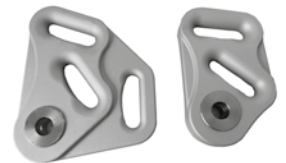

ANTI-TORSION CABLE CLAMPS

For anti-torque cables (dia 9, 11, 13 and 15 mm)
- Can be used for gennaker with Marlow ProDrive +
- Can be used for asymmetric spinnakers with most of the anti-torque cables available on the market
- Material : Duplex grade stainless steel



ANTI-TORQUE CABLES :

Profurl offer anti-torque cables cut at length in various diameter
• Dynex Hampidjan cable - available in 9, 11, 13 and 15 diameter
• Cable Marlow ProDrive2 - available in 9, 11, 13 and 15 diameter



SPLICED FURLING LINES

Available in 8 and 10 mm diameter - From 12 to 26 m. High quality spliced furling line offering higher product lifetime. Prevents the risk to be locked into the spool. More information on page 42



PROTECTION COVER

Our protection covers are available for the NEX spools and swivels as well as for the swivel locks. They will help increase the product lifespan and protect your boat against accidental shocks. Highly resistant, they also have a reflective strip for nighttime.



FLYING SAIL FURLER WITH DRUM

- > With a drum and a single furling line similar to manual headsail furler.
- > Economical system.
- > Easy to install on board

Contact us for more information



Non contractual photo

FLYING SAILS FURLER NEX SPEED

The NEX SPEED is the Racing version of the NEX. Available in NEX2.5 and NEX4.0 versions, they feature the same mechanisms but with more compact spools. It is the perfect unit for regatta and offshore racers looking for enhanced manoeuvrability, performance and weight..

Why choose the NEX SPEED?

- > Quick furling
- > Light and compact
- > Strength (working load: 2.5T & 4T)

User programme for the NEX SPEED

- > Sport boats
- > Single-hulled, type Figaro 3, L30, etc.
- > Foil catamarans type TF35, multi-hulled type GC32
- > Class 40

	NEX 2.5 SPEED	NEX 4.0 SPEED
Light sail area (i.e gennaker)*	80 m ²	140 m ²
Ratchet feature FurlAssist	√	√
Working load **	2500 Kg	4000 Kg
Spool diameter	150 mm	180 mm
Standard lower terminal	Clevis pin snap shackle	
Standard upper terminal	D shackle	
Examples for a monohull	Sailing boat 30' 35'	Sailing boat 40'

*: The values shown in the table are for information only and should be verified by a professional taking into account the characteristics of the boat.

** The working loads shown are the maximum working loads of the mechanisms only and are not the loads of the complete system when terminals are included. The product should not be used above these working loads in any circumstances.



SMART TOGGLE® - 4T: wireless load sensor



Improve the boat performance by measuring in real time luff tension!

- For NEX 4.0 flying sail furler (other sizes on demand)
- Easy to install, light & compact
- Waterproof and durable
- Bluetooth connectivity (mobile app or boat's display)

TECHNICAL DATA

- Working load 4T - Pin to pin: 90 mm - Pin dia: 12 mm - Battery Life 2000 hours @ 1Hz

NEX

Flying sail furlers

TECHNICAL DATA

Technical data: spool	NEX 0.9	NEX 1.5	NEX 2.5	NEX 2.5 SPEED	NEX 4.0	NEX 4.0 SPEED	NEX 6.5	NEX 8.0	NEX 12.0
Height pin to pin: A mm	74,1	81,1	100,2	97	115	118	126	137	166,5
Width drum mechanism: B mm	128	160	192	160	234	192	232	263	263
Width fork: C mm	12	15	18	18	19	19	25,1	25,1	25,1
Depth under pin: F mm	18	22	26	26	33	33	39	39	43
Ø pin G mm	8	8	10	10	12	12	14	14	18
Ø spool: mm	119	149	179	149	219	179	219	249	249
Ø continuous line mm	Ø8	Ø8	Ø10	Ø8	Ø10	Ø10	Ø10	Ø10	Ø10
Weight: spool (only) Kg	0,380	0,540	0,995	0,720	1,490	1,160	1,730	2,440	3,198

Technical data : Mount end piece	NEX 0.9	NEX 1.5	NEX 2.5 & NEX 2.5 SPEED	NEX 4.0 & NEX 4.0 SPEED	NEX 6.5	NEX 8.0	NEX 12.0
Snap shackle - part# fig 1, 4 & 5	54100	54100	54101	54102	59206	2957	-
A : Height Axle-arm : (mm)	39,6	39,6	54	65	99,4	94	-
D : Max inner ø (mm)	16	16	21	26	25	17	-
Weight (kg)	0,054	0,054	0,130	0,257	0,27	0,810	-
MxEvo : halyard shackle FIG 2	MxEvo 6 - 11603		MxEvo 8 - 11604	MxEvo 10 - 11605	-	-	-
A (mm)	32		35	43.5	-	-	-
D: Max inner ø (mm)	9		11	15	-	-	-
Weight (Kg)	0,053		0,109	0,022	-	-	-
Solidsheave 3:1: FIG 3		55018	54555	54105	54554	P598050	P591250
A (mm)	-	26,8	29	31	30,5	45,85	56,2
D: Max inner ø (mm)	-	10	12	16	15	23	25
Weight Kg	-	0,113	0,200	0,280	0,350	0,750	1,238

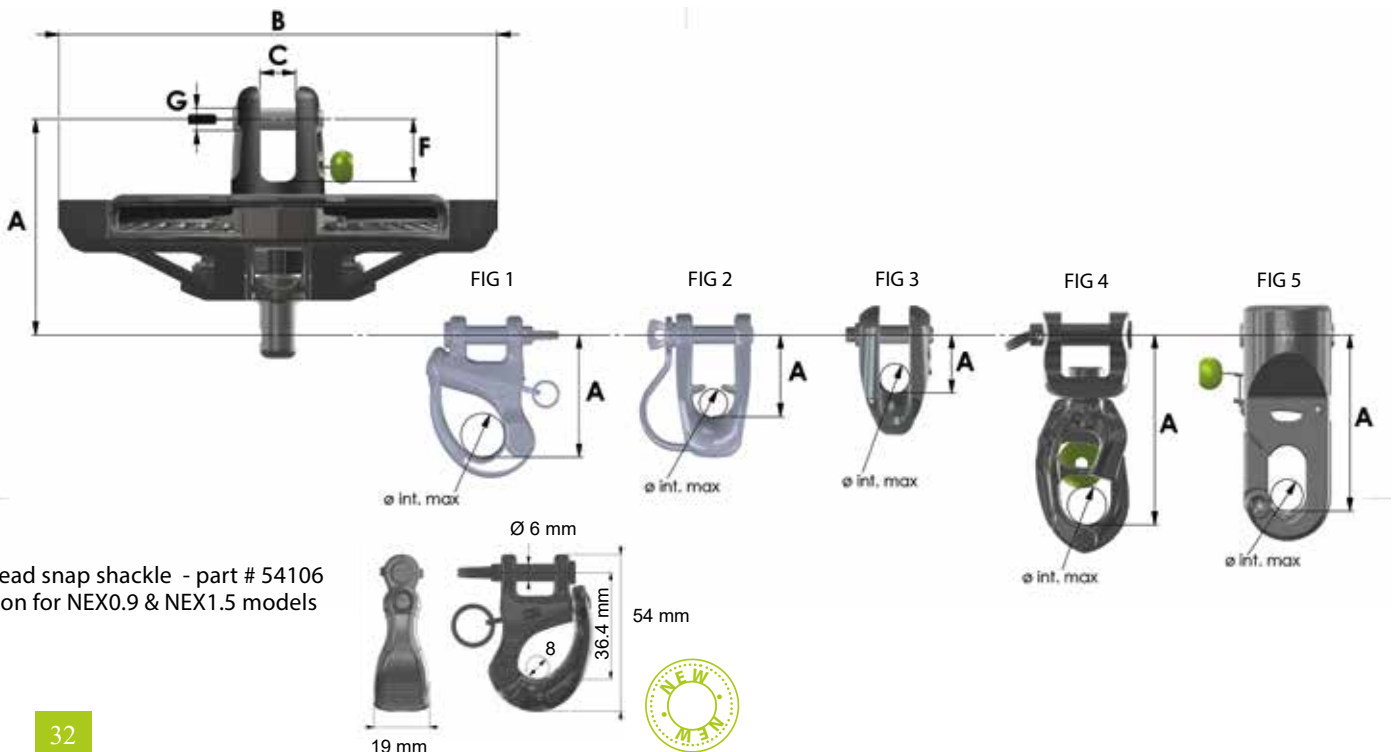

Technical data: swivel	NEX 0.9	NEX 1.5	NEX 2.5 & NEX 2.5 SPEED	NEX 4.0 & NEX4.0 SPEED	NEX 6.5	NEX 8.0	NEX 12.0
Height pin to pin: D mm	63,3	56,2	68,3	82,7	97,7	104,5	128
Width swivel: E mm	31	34	42	50	60	65	72
Width fork: C mm	12	15	18	19	25,1	25,1	25,1
Depth under pin: F mm	18	22	26	33	39	39	43
Ø pin G mm	8	8	10	12	14	14	18
Weight: swivel (only) Kg	0,110*	0,140	0,260	0,470	0,730	0,970	1,638
Max ø luff line mm	9	11	13	15	17	19	21

Technical data : swivel terminals	NEX 0.9	NEX 1.5	NEX 2.5 & NEX 2.5 SPEED	NEX 4.0 & NEX 4.0 SPEED	NEX 6.5	NEX 8.0	NEX 12.0
Wichard HR shackle: Fig 1		Part # 11203	Part # 11204	Part # 11205	Part # 11206	Part # 11207	Part # 11208
ø pin (mm)	-	6	8	10	12	14	16
A / B (mm)	-	24/12	32/16	40 / 20	48/24	56/28	64/32
Weight Kg	-	0,024	0,052	0,102	0,192	0,304	0,464
Eye: Fig 2	Standard	part #p591545	part #p592545	part #594045	part #p596545	part #p598045	part #59248
A (mm)	13,5	20	27,5	35,5	45,8	51,7	NC
D Inner ø. max (mm)	11	13	17	22	28	32	28
Weight (Kg)	0,018	0,034	0,078	0,142	0,287	0,429	1,675
MXEvo : halyard shackle Fig 3		MXEvo 6 part #11603	MXEvo 8 part #11604	MXEvo 10 part#11605	-	-	-
A (mm)	-	32	35	43,5	-	-	-
D:ø int. max (mm)	-	9	11	15	-	-	-
Poids (kg)	-	0,053	0,109	0,222	-	-	-
Halyard block: Fig 4			part #P592530	part #P594030	part #P596530	part #P598030	part #P591230
A (mm)	-	-	24,5	32	38	48	52,5
Sheave ø : B (mm)	-	-	46,4	58	64	80	100
Height : C (mm)	-	-	66	84	96	120	142,5
D: Max Inner ø (mm)	-	-	10	14	16	18	22
Weight Kg	-	-	0,178	0,310	0,505	0,985	1,595

* : incl swivel eye

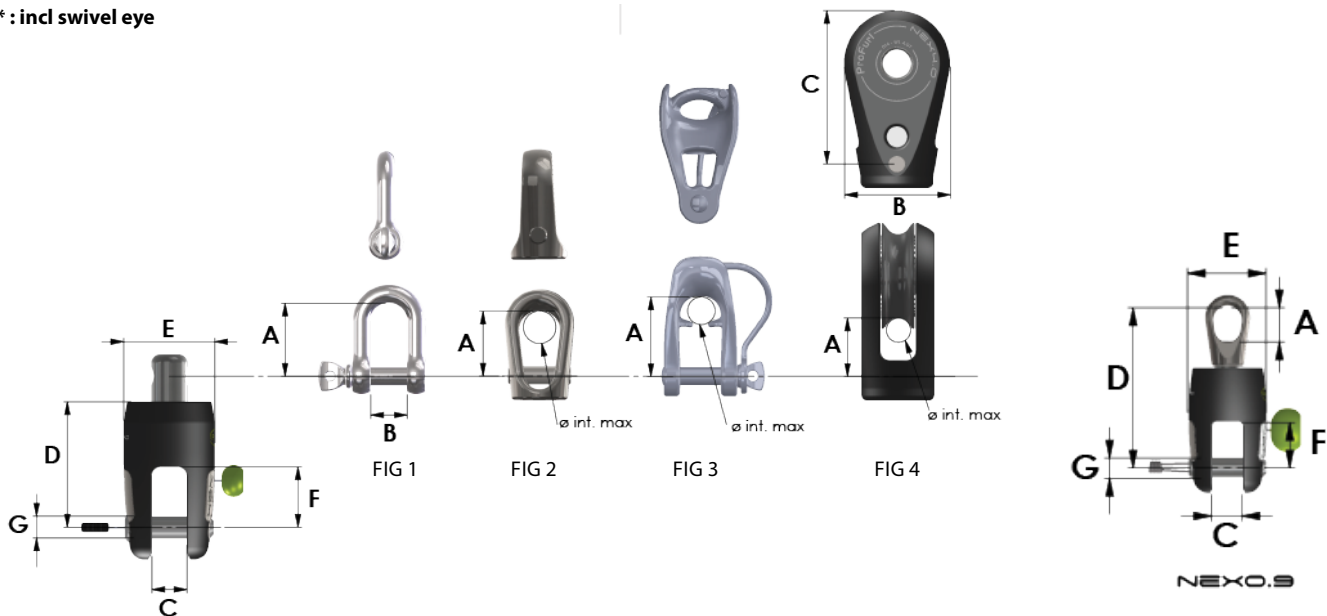

TECHNICAL DATA

Stainless steel thimbles: Fig 1

	NEX 0.9	NEX 1.5	NEX 2.5 & NEX 2.5 SPEED	NEX 4.0	NEX 6.5	NEX 8.0	NEX 12.0
Part #	59164	59025	59026	59027	59028	-	-
A (mm)	40	57	67,5	78	105	-	-
B (mm)	11,5	14,5	17,5	18,5	24,8	-	-
C (mm)	30	38	45	52	70	-	-
ø d (mm)	8,3	8,3	10,3	12,3	14,3	-	-
E (mm)	12	16	18,5	21,5	30	-	-
ø F (mm)	9	11	13	15	20	-	-
Weight Kg	0,030	0,073	0,126	0,190	0,382	-	-

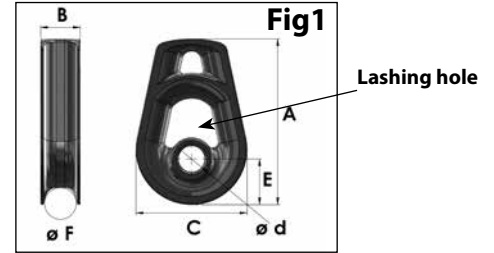

Aluminium thimbles: Fig 2

	NEX0.9	NEX 1.5	NEX 2.5 & NEX 2.5 SPEED	NEX4.0	NEX 6.5	NEX 8.0	NEX12.0
Part #	-	59165	59166	59167	59168	59279	-
A (mm)	-	56	66,5	79	108	119	-
B (mm)	-	14,5	17,5	18,5	24,8	24.8	-
C (mm)	-	38	45	54	70	78	-
ø d (mm)	-	8,3	10,3	12,3	14,3	18.3	-
E (mm)	-	15	17,5	21	31,5	34.8	-
ø F (mm)	-	11	13	15	19	21	-
Weight Kg	-	0,032	0,054	0,074	0,190	0.230	-

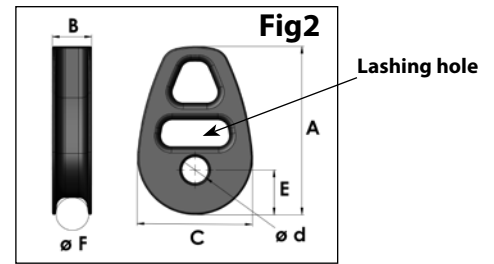

Cableless thimbles: Fig 3

		NEX 2.5 & NEX 2.5 SPEED	NEX 4.0	NEX 6.5	NEX 8.0
Top thimble	Part #	59210	59212	59214	
	A mm	45.50	63.50	81	
	B mm	22*7	27*7	47*12	
	C mm	10	12	14	
	Weight Kg	0.100	0.163	0.349	
Bottom thimble	Part #	59211	59213	59215	
	A mm	50.3	68.25	89.70	
	B mm	22*7	27*7	47*12	
	C mm	10	12	14	
	Weight Kg	0.107	0.177	0.484	

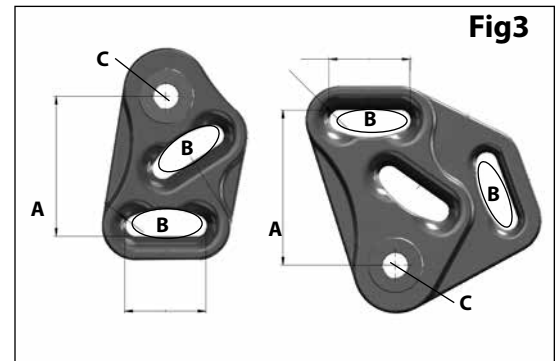

Cable clamps : Fig 4

	NEX 0.9	NEX 1.5	NEX 2.5	NEX 4.0
Part #	7321	7322	7323	7324
Cable size max mm	9	11	13	15
A mm	8.5	10	12	15
B mm	29	31	35	40
L mm	56	60	62	100
Weight Kg	0.169	0.198	0.243	0.525

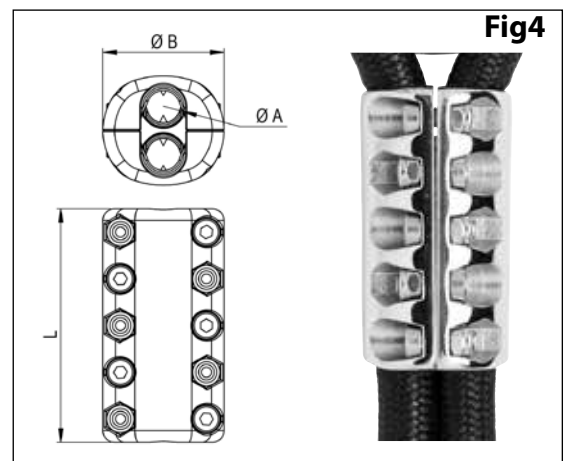



SPINEX

TOP DOWN
SPINNAKER FURLER
WITH RATCHET

Top down spinnaker furler

SPINEX

First launched a decade ago, the next generation of SPINEX includes new innovations to provide even greater user comfort and enhanced furling performance.

SPINEX in short:

- > 6 models available: SPINEX 0.9, SPINEX 1.5, SPINEX 2.5, SPINEX 4.0, SPINEX 6.5 and SPINEX 8.0
- > For boats from 5 to 18m long, and asymmetrical spinnakers up to 400 m²
- > All-in-one system: mechanisms, anti-torque cable, fittings, flexible PVC sleeves, 2-in-1 thimbles, and a swivel tack point
- > The SPIN KIT is available separately for use on NEX reefing systems and other brands on the market (Facnor, etc.)
- > Integrated Profurl technology
- > International 3-year guarantee

Why choose Spinex

Easy to use, safe, efficient, adaptable

Using asymmetric spinnakers in some conditions can be dangerous. With the Spinex, you're going to rediscover the joys of this type of sailing because it allows you to:

- > Easily handle this type of sail (even short-handed)
- > Remain in the safety of the cockpit
- > Improve the performance of your sailing-boat by using downwind sails

Adaptable: One system for many uses

The Spinex can easily be converted into a NEX by removing the swivel tack from the drum and the end fittings, and then it can be used for sails like a gennaker or a code zero.



Innovations in the next generation of SPINEX solutions

Greater furling comfort and performance

Easy to use, offering improved performance for your sailing boat:

- Replacement of the traditional balls with a flexible PVC sheath, offering full UV and twist resistance
- Up to 50% reduced weight
- Easy to store once the sail is furled

Improved furling performance:

- One specific anti-torque cable diameter per model
- Improved furling, adapted to the size of the sails

Easy to install

- A new, innovative 2-in-1 thimble: thimble + clamp for faster installation



Top down furling

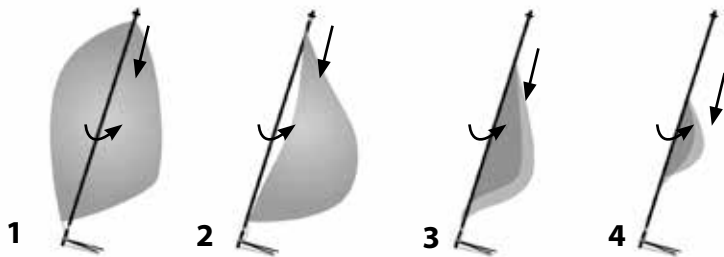

> When it comes to asymmetric spinnakers, top down furling is the best solution for bringing in your sail. The concept first appeared on maxi yachts before filtering down to more modestly-sized sailing-boats.

> Thanks to its swivel tack, the sail can be furled from the top downward to progressively stifle the sail without creating a jam.

Which sails ?

> The Spinex is designed to furl flying sails with a loose luff, such as asymmetrical spinnakers.

> Gennakers, code zeros, staysails and so on can be furled using a NEX furler (see page 24 of this catalogue).



SPINEX Asymmetric spinnaker

NEX {
 Genoa / staysail
 Code 0
 Gennaker

Top down spinnaker furler

SPINEX

SPINEX components

- 1 Innovative ratchet feature : Furlassist
- 2 Large spool diameter
- 3 Innovative thimble: 2 in 1
- 4 Swivel tack point with Dyneema® loop
- 5 PVC sleeves to protect the sail
- 6 Anti-torque cable
- 7 Spool & swivel



FURL ASSIST RATCHET: A MAJOR INNOVATION

A REAL PLUS FOR FURLING OPERATIONS

- Better control of furling
- Avoids accidental unfurling of the sail
- Permanent engagement of the pawl
- Safety: unlocks when hauling in the line fast
- Operates in both directions
- No additional line
- Easy installation and removal (2 screws)

CHOOSE THE RIGHT SPINEX FOR YOU (5–18 M BOATS):

	SPINEX 0.9	SPINEX 1.5	SPINEX 2.5	SPINEX 4.0	SPINEX 6.5	SPINEX 8.0
Boat length (not contractual)	up to 8 m	up to 10 m	up to 12 m	up to 15 m	up to 18 m	+ 20 m
Sail area recommended	up to 60 m ²	up to 100 m ²	up to 150 m ²	up to 230 m ²	up to 300 m ²	up to 400 m ²
Maximum working load	900 Kg	1500 Kg	2500 Kg	5000 Kg	6500 Kg	8000 Kg
Spool diameter	120 mm	150 mm	180 mm	220 mm	220 mm	250 mm
Lower end fitting	Clevis pin snap shackle				Trigger snap shackle	-
Upper end fitting	D shackle					-
Anti-twist cable Ø	9 mm	11 mm	13 mm	15 mm	17 mm	19 mm
Cable length delivered as standard	14 m	17 m	20 m	25 m	30 m	35 m

*: The working loads shown are the maximum working loads of the mechanisms (spool and swivel) only and are not the loads of the complete system when terminals are included. The product should not be used above these working loads in any circumstances.

SPINEX: content



Are you already using a Profurl NEX furler and want to furl your asymmetric spinnaker? Get the SPIN KIT!

Use Profurl's SPIN KIT to turn NEX furlers into asymmetric spinnaker furlers. SPIN KIT includes anti-twist cable, soft sleeves, and upper and lower end fittings.

	SPIN 0.9	SPIN 1.5	SPIN 2.5	SPIN 4.0	SPIN 6.5	SPIN 8.0
Boat length (not contractual)	up to 8 m	up to 10 m	up to 12 m	up to 15 m	up to 18 m	+ 20 m
Part #NEX	NEX 0.9	NEX 1.5	NEX 2.5	NEX 4.0	NEX 6.5	NEX 8.0
Cable length delivered as standard	14 m	17 m	20 m	25 m	30 m	35 m

Top down spinnaker furler

SPINEX

ADVICES FOR USING THE SPINEX

1st time:

> When setting for the first time, we recommend you do this in light winds. Check all halyard and sheet leads.

Furling:

> Tension must be applied to anti-twist cable by hauling on the halyard. It should be taut and stable. Be careful not to apply excessive tension, especially when you use an electric winch.

Direction of furling:

> As the anti-twist cable is a shape-memory component, we recommend you always furl your sail in the same direction to facilitate handling.

Wind angles:

> When unfurling the sail, stay within an apparent angle of between 90 and 120 degrees to help setting.

When furling, the apparent angle must be within 130 and 150 degrees (with the mainsail set to the head of the mast).



INSTALLATION ADVICES

Fig 1.1

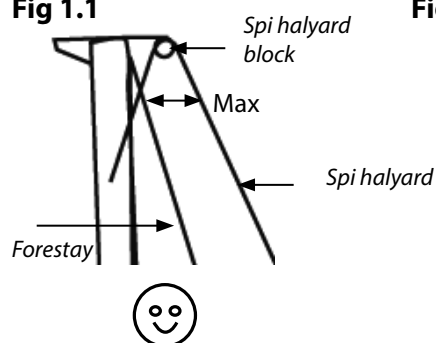

Fig 1.2.

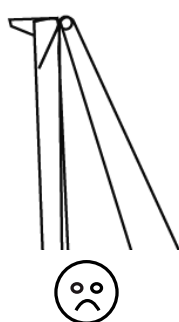

Fig 2.1.

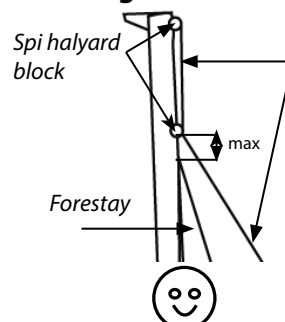

Fig 2.2

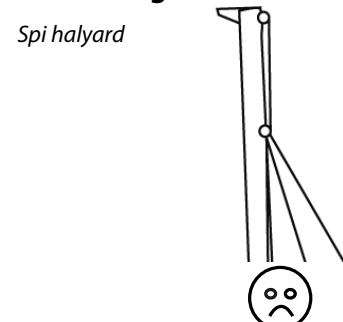

Fig 3.1



Fig 3.2.



Fig 4.1

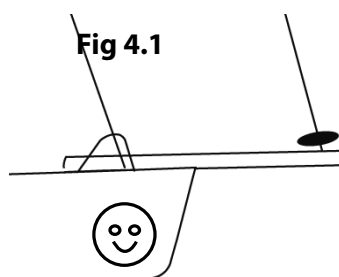
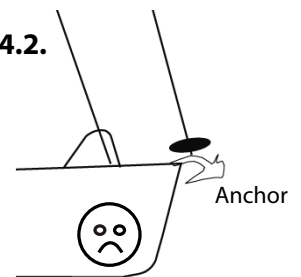

Fig 4.2.



Technical data: SPINEX

	SPINEX 0.9	SPINEX 1.5	SPINEX 2.5	SPINEX 4.0	SPINEX 6.5	SPINEX 8.0
A mm	113.80	120.70	154	180.70	225.40	-
B mm	63.30	80.20	100.30	122.70	146.10	160
C mm	80	87	93	103	126	126
D mm	31.50	35	40	47.10	55.40	56.40
E mm	127.50	139.50	151.50	163	209	216
F mm	34	37	42	47	53	60
G mm	19	21	25.50	28.50	33	33
H mm	8.30	8.30	10.30	12.30	14.30	14.30
I mm	10	10	12	14	17	18
∅ spool: mm	120	150	180	220	220	250
∅ furling line: mm	8	8	8 - 10	8 - 10	10	10
∅ anti-torque cable mm	9	11	13	15	17	19
Weight: swivel tack point, lower thimble Kg	0.490	0.620	0.830	1.060	1.870	1.880
Weight: upper thimble Kg	0.120	0.170	0.245	0.310	0.580	0.590
Weight: cable & sleeve per meter (Kg / m)	0.160	0.210	0.275	0.345	0.420	0.500

Technical data for mechanism

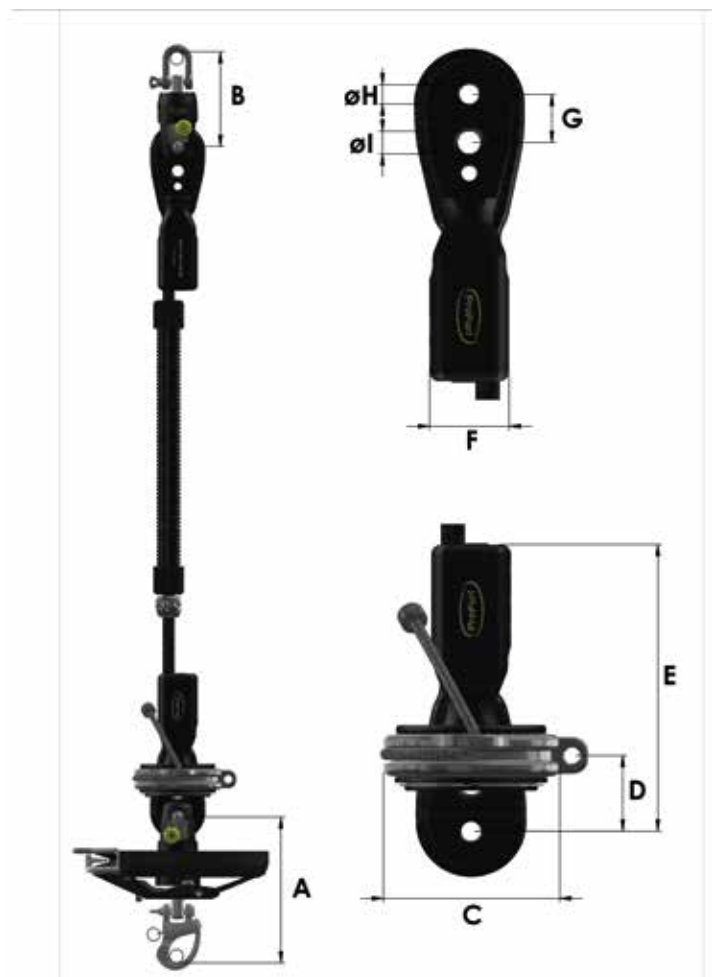

Accessories

for furlers and flying sail furlers



20120



21020

Part #	Description	Applications
20120	Stainless steel single fairlead For 25mm stanchion Maximum line diameter : 20mm	For manual headsail, flying sail and stayfurlers with drum
21020	Deck fairlead – M10 screw	For manual headsail, flying sail and stayfurlers with drum
20220	Stainless steel double fairlead with Velcro stripe for continuous line. For 25mm stanchion maximum Maximum line diameter : 20mm -	For flying sail and stayfurlers with spool
21220	Stainless steel double fairlead with Velcro stripe for continuous line. For 28mm stanchion maximum Maximum line diameter : 20mm	For flying sail and stayfurlers with spool
21120	Stainless steel articulated fairlead - For 25 & 28mm stanchion maximum Maximum line diameter : 20mm	For manual headsail, flying sail and stayfurlers with drum
20320	Deck fairlead - max rope size: 18 mm Fitting with 2 M5 screws	For manual headsail, flying sail and stayfurlers with drum



20220 /
21220



21120



20320

NEX AND SPINEX FLYING SAIL FURLERS: SPliced FURLING LINES – STANDARD LENGTH POLYESTER BRAID / BEIGE

For models	Line Part #	Description
NEX 0.9, SPINEX 0.9	54122	Dia 8 mm - standard length L: 12 m
	54123	Dia 8 mm - standard length L: 14 m
	54124	Dia 8 mm - standard length L: 16 m
NEX1.5, NEX 2.5, NEX 4.0, NEX6.5 - SPINEX 1.5, SPINEX 2.5, SPINEX 4.0	54129	Dia 10 mm - standard length L: 14 m
	54125	Dia 10 mm - standard length L: 16 m
	54126	Dia 10 mm - standard length L: 18 m
	54127	Dia 10 mm - standard length L: 20 m
	54128	Dia 10 mm - standard length L: 22 m
	54131	Dia 10 mm - standard length L: 24 m
54174	Dia 10 mm - standard length L: 26 m	

MANUAL HEADSAIL FURLERS: SPliced FURLING LINES – STANDARD LENGTH

For models	Line Part #	Description
C260, C320, R250, R350	P250901	20 m reefing line ø. 6 + 1 articulated fairlead# Wichard 21120 + 3 single fairleads # Wichard 20120
C290, C350, C420, C430, R350, R420, R430	P250902	25 m reefing line ø. 8 + 1 articulated fairlead# Wichard 21120 + 4 single fairleads # Wichard 20120
C350, C420, C430, C480, R350, R420, R430, R480	P250903	25 m reefing line ø. 10 + 1 articulated fairlead# Wichard 21120 + 4 single fairleads # Wichard 20120
C430, C480, C520, C530, R420, R430	P250904	30 m reefing line ø. 10 + 1 articulated fairlead# Wichard 21120 + 5 single fairleads # Wichard 20120





NDE2 / NDH2 MOTORIZED FURLERS



NDE2 / NDH2: Motorized furlers

All Profurl motorized furlers have been developed to bring you comfort, reliability & safety.

For the NDE2 C350, C420 and C430, Profurl has developed a new engine power system (multi-motor) that make furlers more economic and compact to gain space on the deck.

NDE2 C480, C520, C530 & C600 benefit from the NDE Profurl technology (mono motor) developed and experienced for more than 30 years. These furlers are specifically dedicated to boats from 14m.

Benefits of the motorized systems

- > Easy operations and without effort
- > Safety: operations from the cockpit
- > Ideal for solo or short-handed sailing
- > Large range of systems.
- > Great comfort with minimal noise.
- > Easy installation on the existing forestay.
- > Low power consumption & minimal noise.
- > Capability to convert a manual furler into a motorized furler
- > 2 or 3 year world wide limited warranty.



NDE2 C420

NDE2 C600

NDE2: ELECTRIC MODELS

	NDE2 C350	NDE2 C420	NDE2 C430	NDE2 C480	NDE2 C520	NDE2 C530	NDE2 C600
Boat length	from 11 to 13.50 m	from 13 to 15 m	from 14 to 16 m	from 14,5 to 18,5 m	from 16,5 to 18,5 m	from 18,5 to 22 m	+ 22 m
Forestay dia	8 / 10* mm	10 / 12.7* mm	12,7 mm	14,3 mm	16 / 19 * mm	19 mm	22* mm
Forestay length	14 m	16 m	18 m	18 m	20 m	22 m	24 m
Power	400 W	800 W		24V: 1200 W - 12V: 800W			
Circuit breaker / Power supply	24V: 30 A 12V: 60A	24V: 30 A 12V: 60A		24V: 30 A 12V: 60A			24V: 40A 12V: 60A
Optimal / Max torque	45 / 115 Nm	55 / 135 Nm		24V: 80 / 300 Nm 12V: 78 / 200 Nm			
Optimal rotating speed	40 tr / min	55 tr / min		33 tr / min			
Warranty	2 year	2 year		3 year			

NDH2: HYDRAULIC MODELS

- > 4 models available for boats from 14.50 to 22 m.
- > Available in "Cruising" version (with round extrusions).
- > Connection of the gear motor to the hydraulic pack with 2 feeding hoses finished by a female 7/16" JIC.
- > Turnbuckle cylinder included on all models
- > Length of the extrusion: 2 m.

NDH2: HYDRAULIC MODELS

	NDH2 C480	NDH2 C520	NDH2 C5 30	NDH2 C600
Boat length	from 14,5 to 18,5 m	from 16,5 to 18,5 m	from 18,5 to 22 m	above 22 m
Forestay diameter	14,3 mm	16 / 19 * mm	19 mm	22* mm
Forestay Length	18 m	20 m	22 m	24 m
Maximum operating pressure	140 bars			
Max torque	300 Nm			
Maximum flow recommended	15 L / mn			
Maximum speed of rotation	30 Rpm			
Warranty	3 year			



Monocoque 55'



53320



53310

More comfort on board

- > Wired remote controller Part # 53320
- > Radio remote controller Part # 53310

*: if using a swageless eye



NDE2 / NDH2: Motorized furlers



TOTAL COMFORT AND TOTAL SECURITY

When you choose a Profurl motorized furler, comfort and ease of use come guaranteed, allowing you to get the most out of your sailing.

- > Navigation without any physical effort required through the command box (wired or remote-control options available)
- > The sail can be furled in either direction
- > Generates minimal noise
- > No specific upkeep required
- > The auto-locking mechanism prevents the sail from unfurling at inopportune times
- > The circuit breaker lets you cut supply in an emergency (jammed genoa sheet, incorrect manoeuvre, etc.)
- > In case of problem, the emergency system will let you furl or unfurl the sails manually



PROVEN RELIABILITY

Our NDE2 / NDH2 furlers have been designed to offer unmatched reliability, whatever the sailing conditions:

- > 30 years of experience designing gearmotor reducers
- > The structure and the design of our NDE2 / NDH2 reducers is based on more than 20 years of developing NDE systems
- > The use of high-quality materials ensures enhanced durability and longevity
- > Carefully selected surface treatment ensures effective corrosion resistance
- > The robust extrusions support higher torque couples
- > The vent eliminates any internal condensation (only for models from NDE2 C480, to NDE2 C600)
- > Highly resistant and ISO 10133 compliant electrical cables (only for models from NDE2 C480, to NDE2 C600)



PERFORMANCE

Profurl furlers have a specially designed motor system which lets you manoeuvre the sails quickly, easily and repeatedly.

- > The torque / speed ratio is optimal, meaning you can unfurl and furl in all sailing conditions
- > Power consumption is a crucial feature on a motorized system; the Profurl systems require a low power supply, making special batteries unnecessary



EASE OF INSTALLATION

- > Can be adjusted to suit your existing forestay
- > NDE2 / NDH2 furlers are available in a range of assembly configurations (stainless steel tube or link plates) meaning they can be adapted to suit the layout of your deck
- > The capacity of the turnbuckle cylinder is increased by 100 mm for the C520, C530, C600 (Ø 22mm forestay with turnbuckle).



MODERN DESIGN

The new design means they can be used on all deck layouts and modern sail designs, having already been used on major sailing boats (Amel 50, CNB 66).



SAFETY

In case of power supply failure, the PROFURL motorized system includes a handle socket (handle supplied) located at the rear of the housing, allowing for instant manual operation.



MOTORIZATION KIT:

Capability to convert a Profurl manual furler into a motorized furler by keeping the extrusions. For other brands, contact us.



*Sailing becomes
a pleasure!*



NEX^e

**MOTORIZED
FLYING SAILS FURLER**

NEX^e

Motorized flying sails furler

OPERATING FLYING SAILS SAFELY AND WITHOUT EFFORT

NEX^e is a motorized flying sail furler dedicated to operate large sails like spinnaker, gennaker or code 0 on sailing boats. When sailing short-handed, the operation of large sails on 45 – 60 foot sailboat can be complicated. NEX^e aims at easing furling and jibing operations by controlling the sail safely and without effort. NEX^e is available in 2 sizes: NEX^e Lite4.0 & NEX^e 8.0 for sails up to 250 sqm.

Benefits of motorized flying sail furler NEX^e

- > Easy operations and without effort
- > Safety: operations from the cockpit
- > Ideal for solo or short-handed sailing
- > Fast furling operation
- > Easy to install
- > No accidental release of the sail
- > Reliable: Tested in all weather conditions
- > Sealed unit – no maintenance
- > 3 year worldwide warranty.



Types of sails

- ↳ > Gennaker
- > Code 0
- > Asymetrical spinnaker (with swivel tack point)

Average sail area

- ↳ > Gennaker max sail area: from 140 to 300 sqm
- > Asymetrical spinnaker max sail area: from 200 to 400m²

A comprehensive range - 2 models

Profurl offers you 2 models - NEX^e Lite 4.0 and NEX^e8.0 - which cover most boat sizes.

↘ NEX^e 8.0: for yachts above 50'

- 1st model to be launched in 2018
- Mono-engine proven and robust technology
- Sail area: above 140 m² and up to 300 m²
- Integrated anti-shock casing and ergonomic handle
- No accidental sail unfurling
- Available in 12V and 24V

↘ NEX^eLite 4.0: compact and light for medium boats

- New model launched in 2022
- Compact and light
- Multi-engine technology
- For sails up to 140 m²
- No accidental sail unfurling
- Available in 12V
- Delivered with protection cover and storage bag



NEX^e 8.0



NEX^eLite 4.0

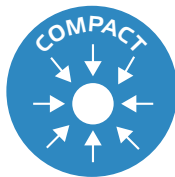

New waterproof deck socket available on the NEX^eLite 4.0

NEX^e range



	NEX ^e LITE 4.0	NEX ^e 8.0
Boat length	from 11.5 m to 16 m from 38 ft to 52'	from 16 m
Gennaker max sail area	140 m ²	300 m ²
Asymmetrical spinnaker max sail area	200 m ²	400 m ²
Pin diameter	12 mm	14 mm
Power	400 W	800 W
Power supply	12V (24V on request)	12V or 24V
Circuit breaker	35A	40A (12V) - 30A (24V)
Optimal rotating speed	85 rpm (12V)	110 rpm
Power consumption	20 - 25A / h	-
Cable length	7 m	1.5 m
Motor unit weight	5 Kg	11.6 Kg
Power supply box	incl.	incl.
Worldwide warranty	2 year	3 year

Manual flying sail furler replacement

Your boat is already equipped with a manual furler and you want to go electric? No problem, thanks to the motorization conversion kit, you can go electric. This kit only includes the gear box, and you will keep using your current swivel. The motorization kit is available for both models NEXeLite 4.0 and NEXe 8.0.

NEX^eLITE 4.0 - Components

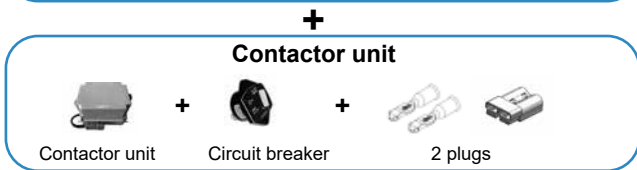
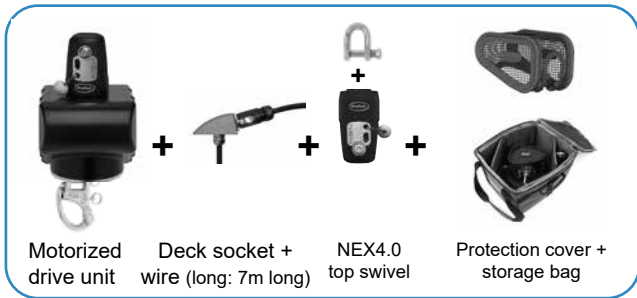

NEX^e8.0 - Components

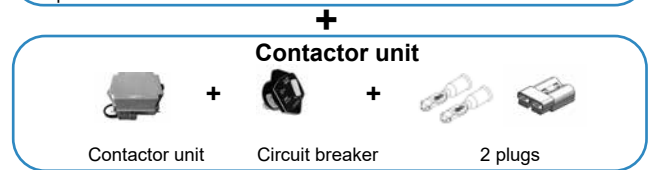
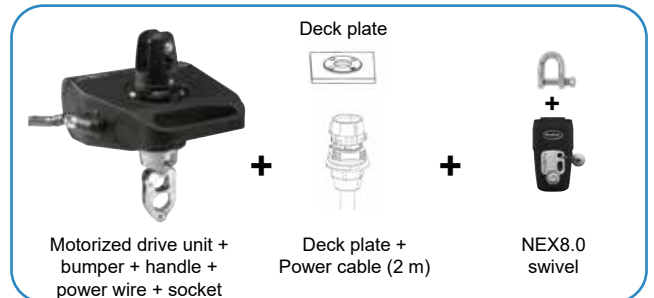

Options

- > Wired remote controller Part # 53320
- > Radio remote controller Part # 53310
- > Halyard blocks



Spinnaker version

Spinkit package

Swivel tack point, soft sleeves, thimbles



Technical data: NEX^e

Dimensions

	NEX ^e lite 4.0	NEX ^e 8.0
A	216 mm	278 mm
B	244 mm	318 mm
CxD	19 x 33 mm	25.1 x 36.5 mm
E	dia 12 mm	dia 14 mm
F x G	106 x 138	221 x 252
Weight	5 Kg	11.6 Kg

NEX^eLite 4.0

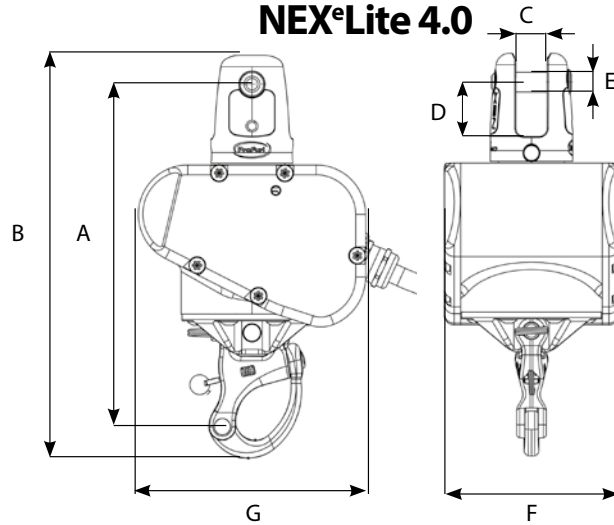

NEX^e 8.0

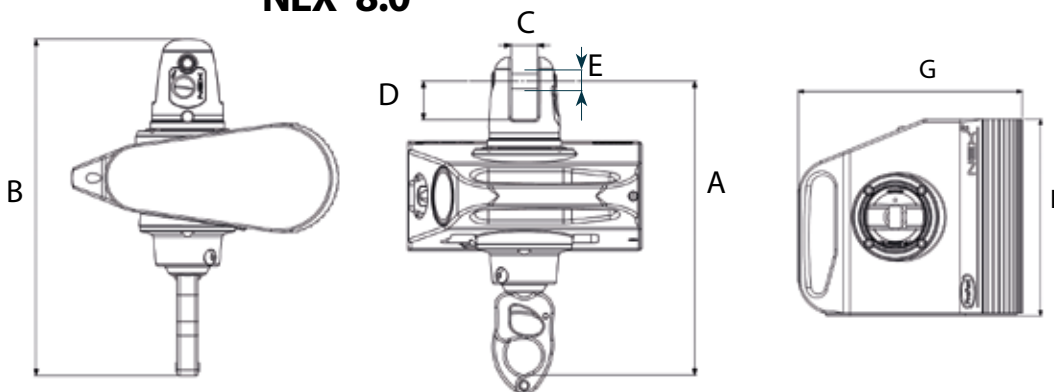

Swivel tack point Dimensions

NEX^e 8.0

A	178,30 mm
B	128,00 mm
C	133,35 mm
D	25,10 mm
E	40,50 mm
F	22,00 mm
Ø G	14,00 mm
Ø H	14,00 mm
I	81,70 mm
J	23,00 mm
K	20,00 mm
L	10,00 mm

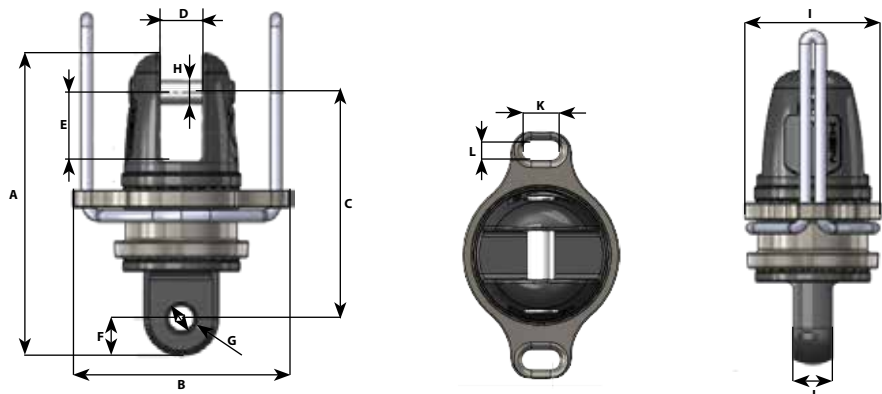



OCEAN RACING



**SWIVEL LOCKS
FLYING SAIL FURLERS
STAYFURLERS**

IMOCA PRODUCTS RANGE

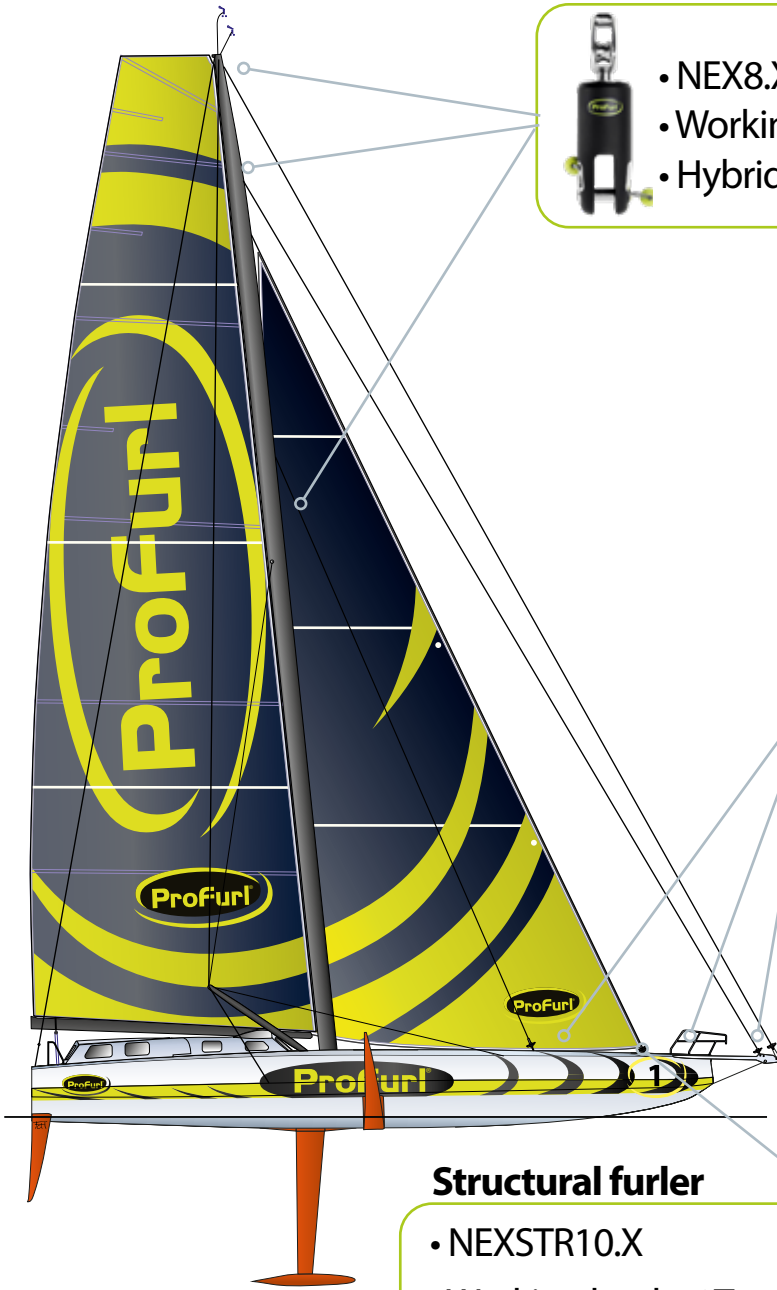

Swivel locks for headsails



- NEX8.X
- Working load: 8T
- Hybrid bearings

VOILES - SAILS
J0, J0.5
J1, J3

Flying sail furlers

- NEX8.X
- Working load: 8T
- Spool or drum
- Terminals: solidsheave, purchase, eye

VOILES - SAILS
J0, J0.5
J1, J3



Structural furler

- NEXSTR10.X
- Working load: 10T
- Drum version
- Cunningham tensioning: Powertack - Tack+

VOILES - SAILS
J2



Standard



PowerTack



Tack+

CLASS 40

PRODUCTS RANGE

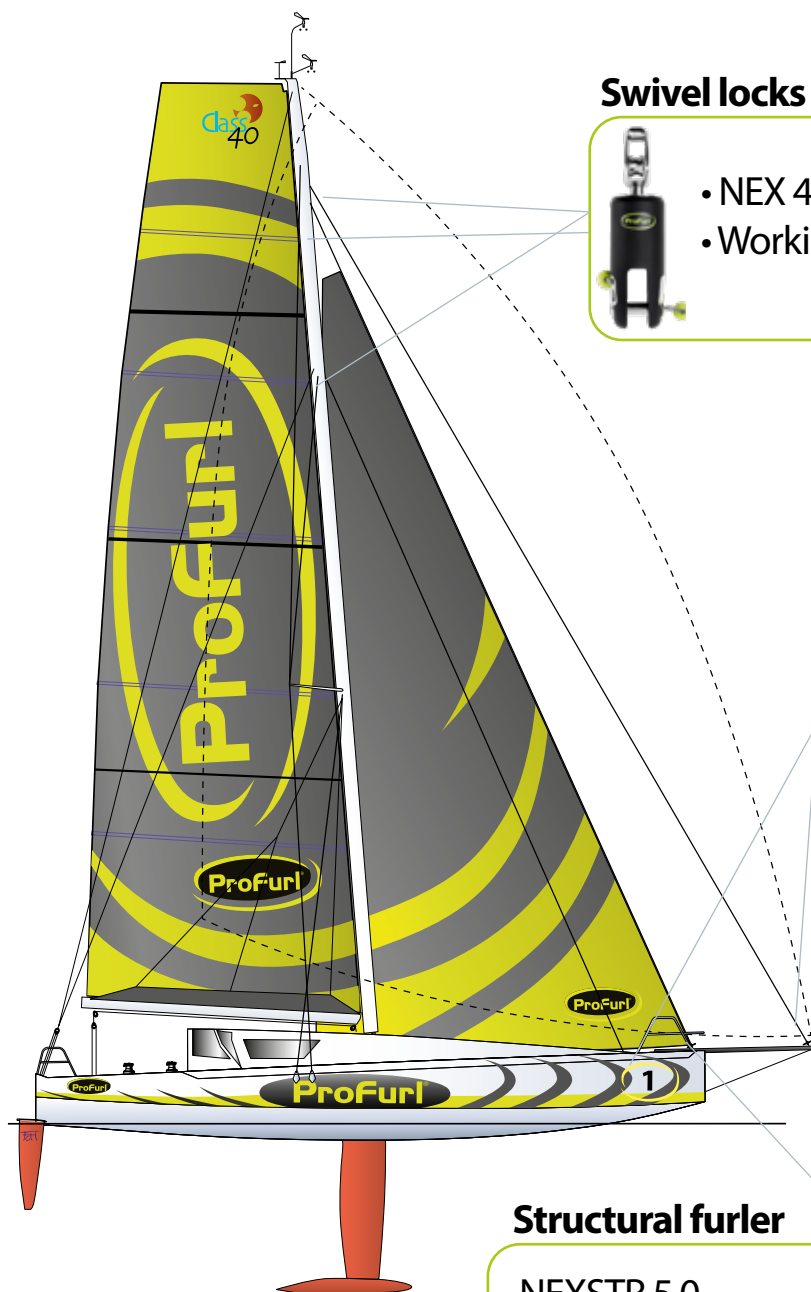

Swivel locks for headsails



- NEX 4.0
- Working load: 4T



Flying sail furlers

- NEX4.0 or NEX4.0 Speed
- Working load: 4T
- Spool as a standard
- Terminals: snap shackle, solidsheave



Structural furler

- NEXSTR 5.0
- Working load: 5T
- Drum version
- Lower terminals: lashing eye, double-jaw toggle, purchase
- Upper terminals: lashing eye



SWIVEL LOCKS

SWIVEL LOCKS FOR FLYING SAILS

A comprehensive range of swivel locks with proven reliability for many years. Tested at sea during the last 2 Vendée Globe editions - including the victory of Maitre Coq in 2022. The Profurl swivel locks are in growing demand on fast cruising boats



Compatibility - NEX model	Description	WL / BL	Fork width	Pin Ø	Halyard Ø	Weight	Part #
NEX2.5	2.5 Swivel lock	2.5T / 5T	18 mm	10 mm	6 mm	425 gr	P592535
NEX4.0	4.0 Swivel lock	4.0T / 8.0T	19 mm	12 mm	7 mm	665 gr	P594035
NEX12.0	12.0 Swivel lock	12.0T / 24T	25.1 mm	18 mm	11 mm	2200 gr	P591235
Compatibility - NEX.X model	Désignation	WL / BL	Fork width	Pin Ø	Halyard Ø	Weight	Part #
NEX8.X	6.X Swivel lock	6T / 12T	22 mm	14 mm	10 mm	1270 gr	P596535
NEX8.X	8.X Swivel lock	8T / 16T	22 mm	18 mm	10 mm	1405 gr	P559038

WL: working load / BL: breaking load

Some boats equipped by Profurl

- > 60 feet IMOCA: Bureau Vallée 3, Holcim/PRB, Arkea, Malizia, Maitre Coq
- > Class 40
- > Maxi trimaran solo Banque Populaire VII
- > Maxi trimaran Spindrift 2
- > Mega Yachts

and some records:

- > **Vendee Globe 2020 / 2021: 1st place** Yannick Bestaven on Maître Coq IV - 3rd place : Louis Burton on Bureau Vallée II
- > **Route du Rhum 2022:** 1st place (Ultim, Imoca, Class 40)
- > **Transat Jacques Vabre:** 1st Place - Class 40
- > **Jules Verne Trophy:** record on IDEC Sport



Accessories:

Protection covers range



FLYING SAILS FURLER

FLYING SAILS FURLER: NEX8.X

Type of boats: IMOCA, fast cruising boats > 55 feet

Imoca sails example	Mechanism	WL / BL	Fork width	Pin Ø	Overall weight*	Terminals	Part #
J0, J0.5, J1	Spool	8T / 18T	22 mm	18 mm	2380 gr	Solidsheave	P558316
J0, J0.5, J1	Spool	8T / 18T	22 mm	18 mm	1980 gr	W/O terminals	P558312
J0	Top down spool	8T / 18T	22 mm	18 mm	2830 gr	Solidsheave	P558380
J3	Drum	8T / 18T	22 mm	18 mm	2800 gr	Solidsheave	P558318
J3	Spool	8T / 18T	22 mm	18 mm	2280 gr	Purchase	P558317
J3	Drum	8T / 18T	22 mm	18 mm	2700 gr	Purchase	P558319
-	Drum	8T / 18T	22 mm	18 mm	2400 gr	W/O terminals	P558313

* overall weight also includes terminals weights. WL: working load / BL: breaking load



FLYING SAILS FURLER: NEX4.0 & NEX4.0 Speed

Type of boats: Class 40, fast cruising boats < 55 feet



With ratchet feature:
FURLASSIST

Type of sails	Mechanism	WL	Fork width	Pin Ø	Spool Ø	Spool weight	Model
J0, J1, J3	Spool	4T	19 mm	12 mm	219 mm	1490 gr	NEX4.0
J0, J1, J3	Spool	4T	19 mm	12 mm	179 mm	1160 gr	NEX4.0 Speed

To be combined with the swivel lock part # P594035 or just the standard swivel
Range of terminals available: snap shackle, solid sheave, halyard block, eye...

WL: working load

Stayfurlers :

NEX
STRUCTURAL

STAYFURLERS: NEXSTR

Sails example	WL / BL	Lower terminal	Upper terminal	Fork width	Spool weight	Swivel weight	Part #
NEXSTR 5.0 (drum & swivel)							
Class 40 / J2	5T / 10T	Lashing eye	Lashing eye	20 mm	2220 gr	1090 gr	NEXSTR 5.0-CDLL
Class 40 / J2	5T / 10T	Double-jaw toggle	Lashing eye	20 mm	2260 gr	1090 gr	NEXSTR 5.0-CDEL
Class 40 / J2	5T / 10T	Purchase	Lashing eye	20 mm	2350 gr	1090 gr	NEXSTR 5.0-CDPL



Purchase



Lashing eye



Double-jaw toggle



Sails example	Description	WL / BL	Terminals	Width fork	Weight	Part #
NEXSTR 10.X						
IMOCA / J2	Standard version: Drum	10T / 20T	to be defined	22 mm	2930 gr	P5690213
IMOCA / J2	Drum version: POWERTACK	10T / 20T	Purchase	22 mm	4100 gr	P5690713
IMOCA / J2	Drum version TACK+	10T / 20T	Purchase	22 mm	5200 gr	P5690615
IMOCA / J2	Top swivel	10T / 20T	To be defined	22 mm	1080 gr	P5690313



Standard version: drum



Powertack version



Tack+ version

POWERTACK & TACK+: J2 cunningham trimming

INNOVATION & PERFORMANCE

- Perfect system enabling to adjust the sail cunningham
- Sail profile optimization
- Designed for headsail geared on stayfurlers (J2 - Imoca)
- Specifically developed for offshore racing
- Tested by Holcim-PRB and Malizia during The Ocean Race 2023.

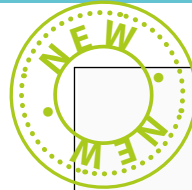

Tack+ version - with inner swivel

AVAILABLE IN 2 VERSIONS

- **Tack+** : with inner swivel
- **Powertack**: cunningham line trimmed directly by external purchase



Powertack version

ACCESSORIES: Tackplate - flying sail furler thimbles

Benefits

- 2 models: lashing or fork
- For flying sails fitted with anti-torque cable or not
- Developed with sailmakers for IMOCA class
- Specific design for a better webbing alignment and load sharing
- For 7T & 8T flying sail furlers
- Suitable with Profurl, Facnor and Karver furlers
- Lightweight
- Material: aluminium & stainless steel



Lashing version

Fork version

TECHNICAL DOCUMENTS

WEIGHT OF THE DIFFERENT COMPONENTS IN KG

Models	Drum mechanism	Turnbuckle cylinder	Complete Swivel	Compleat luff extrusion Kg / m	Head fitting + wrapstop
C290	2,09	included	0,54	0,557	0,16
C320	2,08	0,76	0,58	0,661	0,18
C350	3,12	0,82	0,84	0,728	0,32
C420	3,43	0,87	1,07	0,933	0,38
C430	3,51	0,87	1,73	0,933	0,38
C480	6,06	1,79	2,08	1,2	0,56
C520	6,06	2,22	2,08	1,46	0,57
C530	6,06	2,22	2,37	2,8	0,57
R250	1,6	0,45	0,51	0,383	0,06
R350	2,16	0,63	0,85	0,638	0,18
R420	3,75	0,94	0,98	0,835	0,36
R430	3,75	0,94	1,68	0,835	0,36
R480	6,09	1,79	2,08	1,2	0,44

DRUM CAPACITY FOR HEADSAIL SYSTEMS AND SUGGESTED FURLING LINE DIAMETERS

Model	Ø Forestay mm (")	Boat length m (ft)	Forestay length	Max. genoa area	Ø luff mm (inch)	Ø furling line mm (inch)	Drum capacity m (ft)	Maximum LP
C260	5 (13/64")	5 to 8 m	6.5 à 8,5 m	15 m ²	6 (15/64")	6 (15/64")	7,6 m (25')	4 m (13')
C290	6,35 (1/4") / 7* (9/32")	7 to 10 m	10 à 14 m	30 m ²	5 (13/64")	6 (15/64") 8 (5/16")	13 m (42') 7,5 m (25')	8 m (26') 3 m (10')
C320	7 (9/32") / 8* (5/16")	9,5 to 12 m	12 à 16 m	40 m ²	5 (13/64")	6 (15/64") 8 (5/16")	26,2 m (85') 14,7 m (46')	17 m (56') 7 m (23')
C350	8 (5/16") / 10* (3/8")	11,5 to 13,5 m	14 à 18 m	55 m ²	5 (13/64")	8 (5/16") 10 (3/8")	23,2 m (75') 14,9 m (49')	19 m (62') 7 m (23')
C420	10 (3/8") / 12,7* (1/2")	13 to 15 m	16 à 20 m	80 m ²	5 (13/64")	8 (5/16") 10 (3/8")	31,4 m (101') 20,1 m (65')	26 m (86') 12,5 m (41')
C430	12,7 (1/2")	14 to 16 m	18 à 22 m	100 m ²	5 (13/64")	8 (5/16") 10 (3/8")	31,4 m (101') 20,1 m (65')	26 m (86') 12,5 m (41')
C480	14,3 (9/16")	14,5 to 18,5 m	18 à 22 m	120 m ²	6 (15/64")	10 (3/8") 12 (1/2")	30 m (98') 22 m (72')	26,5 m (81') 14,5 m (45')
C520	16 (5/8") / 19* (3/4")	16,5 to 18,5 m	20 à 24 m	140 m ²	6 (15/64")	10 (3/8") 12 (1/2")	30 m (98') 22 m (72')	26,5 m (81') 14,5 m (45')
C530	19 (3/4")	18,5 to 26 m	22 à 26 m	220 m ²	6 (15/64")	10 (3/8") 12 (1/2")	30 m (98') 22 m (72')	26,5 m (81') 14,5 m (45')
R250	6,35 (1/4")	6 à 9 m (19'-30')	8 à 12 m	30 m ²	5 (13/64")	6 (15/64") 8 (5/16")	11,1 m 6,2 m	4,5 m (13') 2,5 m (8')
R350	8 (5/16")	9,5 to 12,5 m (31'-41')	12 - 16 m	45 m ²	5 (13/64")	6 (15/64") 8 (5/16")	26,2 m 14,7 m	17 m (56') 7 m (23')
R420	10 (3/8")	11,5 to 14,5 m (37'-47')	14 - 18 m	70 m ²	5 (13/64")	8 (5/16") 10 (3/8")	31,4 m 20,1 m	26 m (86') 12,5 m (41')
R430	11,1 (7/16")	13 to 16,5 m (43'-54')	16 - 20 m	90 m ²	5 (13/64")	8 (5/16") 10 (3/8")	31,4 m 20,1 m	26 m (86') 12,5 m (41')
R480	12,7 (1/2")	15,5 to 20 m (52'-65')	18 - 22 m	100 m ²	6 (15/64")	10 (3/8") 12 (1/2")	30 m (98') 22 m (72')	26,5 m (86') 14,5 m (45')

INNER DIMENSIONS OF DRUM MECHANISM

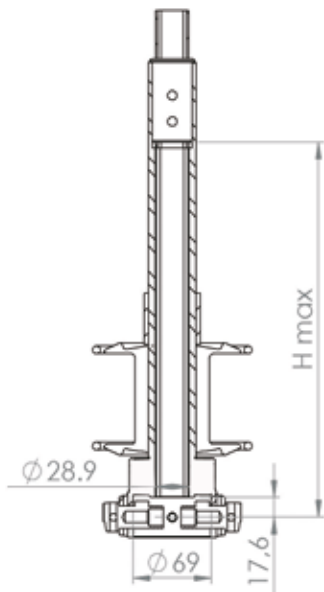

C290 - R250SP

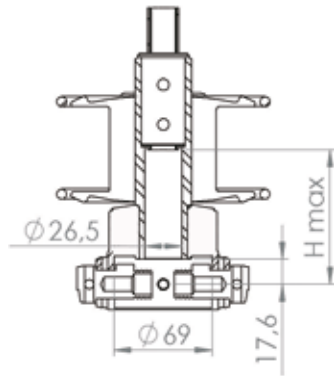

R250

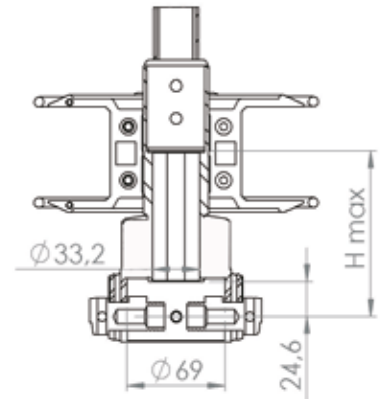

C320 - R350

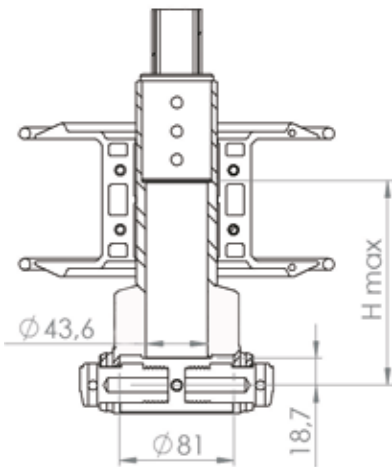

C320SP - C350
C350SP - C420SP
C430SP - R350SP
R420SP - R430SP

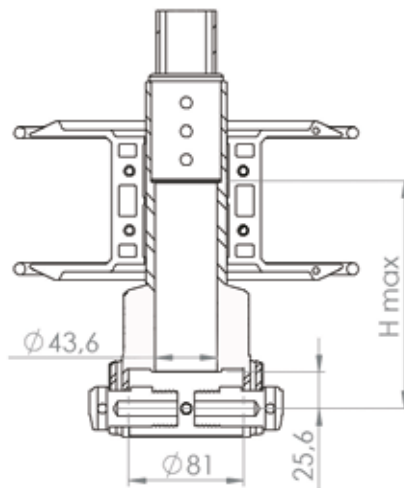

C420 - C430
R420 - R430

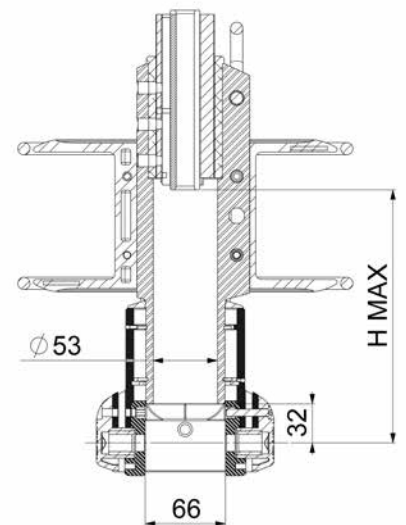

C480 - C520
C530 - R480

DIMENSIONS OF C260 MODEL

	mm	ins
A	150	5 29/32"
B	575	1'10 5/8"
C	26	1 1/32"
D	115	4 17/32"
E	56	2 13/64"
F	56	2 13/64"
G	67	2 41/64"
H	50	1 63/64"

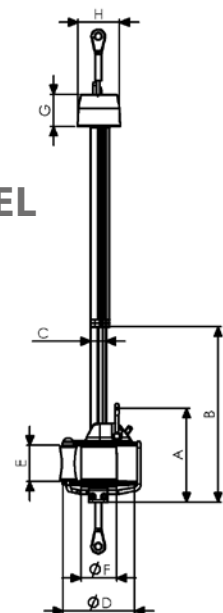

**C290 MODEL &
BELOW DECK FITTING**

DIMENSIONS FOR MODELS FROM C320 TO C430 - R250 TO R430

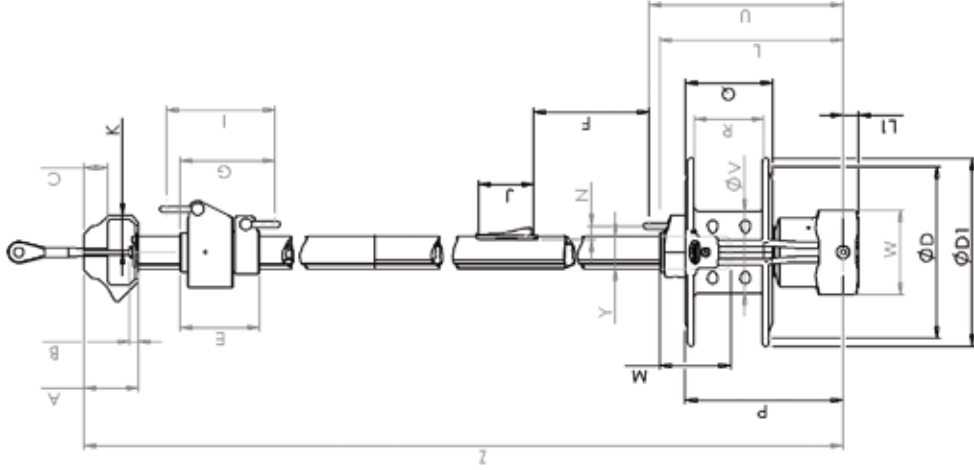
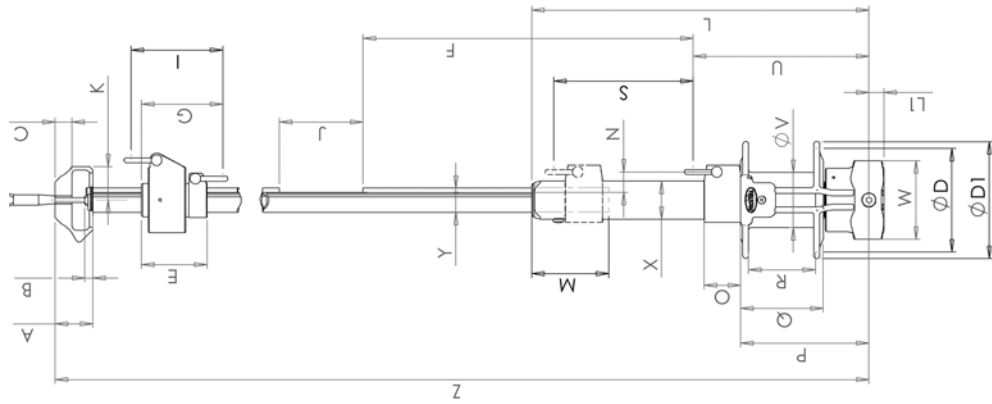

Standard fitting

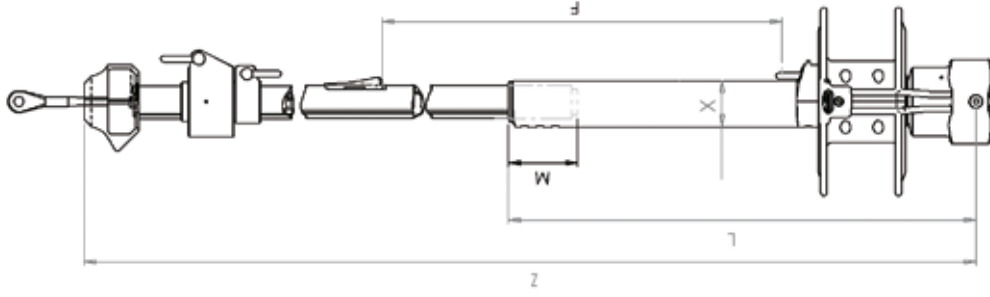

with turnbuckle
cylinder

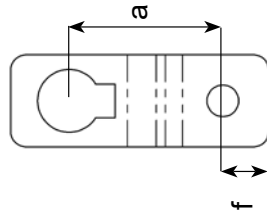
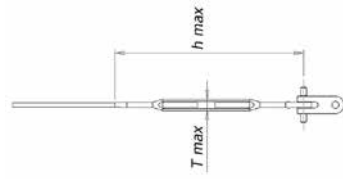

Short link plates

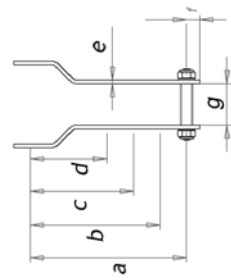

Long link plates

DIMENSIONS OF C290, C320, C350, C420, C430 MODELS

	C290				C320				C350				C420				C430			
	Standard		Turnbuckle cylinder		Standard		Turnbuckle cylinder		Standard		Turnbuckle cylinder		Standard		Turnbuckle cylinder		Standard		Turnbuckle cylinder	
	mm	ins	mm	ins	mm	ins	mm	ins	mm	ins	mm	ins	mm	ins	mm	ins	mm	ins	mm	ins
A	44	1 7/8"	44	1 7/8"	68	2 3/4"	68	2 3/4"	68	2 3/4"	68	2 3/4"	68	2 3/4"	68	2 3/4"	68	2 3/4"	68	2 3/4"
B	10	3/8"	10	3/8"	10	3/8"	10	3/8"	10	3/8"	10	3/8"	10	3/8"	10	3/8"	10	3/8"	10	3/8"
C	22	5/8"	22	5/8"	28	1 1/4"	28	1 1/4"	28	1 1/4"	28	1 1/4"	28	1 1/4"	28	1 1/4"	28	1 1/4"	28	1 1/4"
D	120	4 3/4"	180	7 1/2"	200	7 7/8"	200	7 7/8"	200	7 7/8"	200	7 7/8"	200	7 7/8"	220	8 1/2"	220	8 1/2"	220	8 1/2"
ØD1	140	5 3/4"	200	7 7/8"	222	8 3/4"	222	8 3/4"	222	8 3/4"	222	8 3/4"	242	9 1/2"	242	9 1/2"	242	9 1/2"	242	9 1/2"
E	79	3 1/8"	79	3 1/8"	103	4 1/16"	103	4 1/16"	103	4 1/16"	103	4 1/16"	103	4 1/16"	103	4 1/16"	140	5 3/4"	140	5 3/4"
F	293	11 1/2"	461	16 1/4"	442	15 1/2"	442	15 1/2"	442	15 1/2"	442	15 1/2"	442	15 1/2"	442	15 1/2"	808	2 7/8"	808	2 7/8"
G	96	3 3/4"	96	3 3/4"	125	4 7/8"	125	4 7/8"	125	4 7/8"	125	4 7/8"	125	4 7/8"	126	4 7/8"	170	6 1/16"	170	6 1/16"
Hmax	320	1 5/8"	110	4 21/64"	424	1 4 3/4"	137	5 25/64"	457	1 5 63/64"	154	6 1/16"	154	6 1/16"	154	6 1/16"	154	6 1/16"	154	6 1/16"
I	109	4 1/2"	109	4 1/2"	142	5 19/32"	142	5 19/32"	142	5 19/32"	142	5 19/32"	144	5 3/4"	144	5 3/4"	196	7 3/4"	196	7 3/4"
J	100	3 7/8"	72	2 53/64"	72	2 53/64"	72	2 53/64"	72	2 53/64"	72	2 53/64"	72	2 53/64"	72	2 53/64"	72	2 53/64"	72	2 53/64"
K	33	1 1/4"	33	1 1/4"	47	1 27/32"	47	1 27/32"	47	1 27/32"	47	1 27/32"	47	1 27/32"	47	1 27/32"	47	1 27/32"	47	1 27/32"
L	404	1 3 7/8"	181	7 1/4"	220	8 3/4"	220	8 3/4"	220	8 3/4"	220	8 3/4"	236	9 19/64"	236	9 19/64"	236	9 19/64"	236	9 19/64"
L1	18	45/64"	18	45/64"	20	25/32"	20	25/32"	20	25/32"	20	25/32"	20	25/32"	20	25/32"	20	25/32"	20	25/32"
M	78	35/64"	64	2 33/64"	75	2 15/16"	75	2 15/16"	75	2 15/16"	75	2 15/16"	75	2 15/16"	75	2 15/16"	75	2 15/16"	75	2 15/16"
N	25	63/64"	17	43/64"	21	53/64"	21	53/64"	21	53/64"	21	53/64"	18	45/64"	18	45/64"	18	45/64"	18	45/64"
O	45	1 49/64"																		
P	150	5 29/32"	157	6 3/16"	184	7 1/4"	184	7 1/4"	184	7 1/4"	184	7 1/4"	203	7 1 63/64"	203	7 1 63/64"	203	7 1 63/64"	203	7 1 63/64"
Q	98	3 55/64"	88	3 15/32"	108	4 1/4"	108	4 1/4"	108	4 1/4"	108	4 1/4"	115	4 17/32"	115	4 17/32"	115	4 17/32"	115	4 17/32"
R	80	3 5/32"	66	2 19/32"	66	2 19/32"	66	2 19/32"	66	2 19/32"	66	2 19/32"	90	3 9/16"	90	3 9/16"	90	3 9/16"	90	3 9/16"
S	170	6 11/64"																		
Tmax	29	1 9/64"	32	1 17/64"	42	1 21/32"	42	1 21/32"	42	1 21/32"	42	1 21/32"	42	1 21/32"	42	1 21/32"	42	1 21/32"	42	1 21/32"
U	213	8 25/64"	199	7 53/64"	245	9 41/64"	245	9 41/64"	245	9 41/64"	245	9 41/64"	262	10 1/2"	262	10 1/2"	262	10 1/2"	262	10 1/2"
V	66	2 19/32"	92	3 5/8"	105	4 9/64"	105	4 9/64"	105	4 9/64"	105	4 9/64"	105	4 9/64"	105	4 9/64"	105	4 9/64"	105	4 9/64"
W	97	3 13/16"	97	3 13/16"	115	4 17/32"	115	4 17/32"	115	4 17/32"	115	4 17/32"	115	4 17/32"	115	4 17/32"	115	4 17/32"	115	4 17/32"
X	46	1 13/16"			52	2 3/64"	52	2 3/64"	52	2 3/64"	52	2 3/64"	60	2 23/64"	60	2 23/64"	60	2 23/64"	60	2 23/64"
Y	29	1 9/64"	32	1 17/64"	35	13/8"	35	13/8"	35	13/8"	35	13/8"	42	1 21/32"	42	1 21/32"	42	1 21/32"	42	1 21/32"
Z	10370	34 1/4"	12160	39 10 3/4"	12475	39 10 3/4"	14215	46 7 3/4"	14535	47 8 1/4"	16230	53 2	16230	53 2	16230	53 2	18230	59 9 1/2"	18595	61
Short link plates																				
a	50 (1 31/32")		50 (1 31/32")		55 (2 5/32")		55 (2 5/32")		55 (2 5/32")		55 (2 5/32")		55 (2 5/32")		55 (2 5/32")		55 (2 5/32")		55 (2 5/32")	
f	15 (19/32")		15 (19/32")		20 (25/32")		20 (25/32")		20 (25/32")		20 (25/32")		20 (25/32")		20 (25/32")		20 (25/32")		20 (25/32")	
Link plates																				
a	180	7 3/32"	340	1 1 1/12"	180	7 3/32"	500	1 7 11/16"	200	7 7/8"	500	1 7 3/4"	200	7 7/8"	500	1 7 3/4"	200	7 7/8"	500	1 7 3/4"
b	145	5 45/64"	305	1 1/64"	145	5 7/8"	465	1 6 5/16"	165	6 3/4"	465	1 6 5/16"	165	6 3/4"	465	1 6 5/16"	165	6 3/4"	465	1 6 5/16"
c	110	4 21/64"	270	10 5/8"	110	4 21/64"	430	1 4 7/8"	130	5 1/2"	430	1 4 7/8"	130	5 1/2"	430	1 4 7/8"	130	5 1/2"	430	1 4 7/8"
d	75	2 61/64"	235	9 1/4"	75	2 61/64"	395	1 3 9/16"	95	4 5/16"	395	1 3 9/16"	95	4 5/16"	395	1 3 9/16"	95	4 5/16"	395	1 3 9/16"
e	4	5/32"	4	5/32"	4	5/32"	4	5/32"	4	5/32"	4	5/32"	4	5/32"	4	5/32"	4	5/32"	4	5/32"
f	16	19/32"	16	19/32"	16	19/32"	16	19/32"	16	19/32"	16	19/32"	16	19/32"	16	19/32"	16	19/32"	16	19/32"
g	41	1 39/64"	41	1 39/64"	41	1 39/64"	41	1 39/64"	41	1 39/64"	41	1 39/64"	41	1 39/64"	41	1 39/64"	41	1 39/64"	41	1 39/64"

DIMENSIONS OF R250, R350, R420, R430 MODELS

	R250				R350				R420				R430			
	Standard		Turnbuckle cylinder		Standard		Turnbuckle cylinder		Standard		Turnbuckle cylinder		Standard		Turnbuckle cylinder	
	mm	ins	mm	ins	mm	ins	mm	ins	mm	ins	mm	ins	mm	ins	mm	ins
A	32	1 7/64"	See Standard	See Standard	44	1 47/64"	See Standard	See Standard	68	2 43/64"	See Standard	See Standard	68	2 43/64"	See Standard	See Standard
B	10	13/32"	See Standard	See Standard	10	13/32"	See Standard	See Standard	10	13/32"	See Standard	See Standard	10	13/32"	See Standard	See Standard
C	16	5/8"	See Standard	See Standard	22	55/64"	See Standard	See Standard	28	17/64"	See Standard	See Standard	28	17/64"	See Standard	See Standard
D	130	5 1/8"	See Standard	See Standard	180	7 3/32"	See Standard	See Standard	220	8 21/32"	See Standard	See Standard	220	8 21/32"	See Standard	See Standard
ØD1	150	5 29/32"	See Standard	See Standard	200	7 7/8"	See Standard	See Standard	242	9 17/32"	See Standard	See Standard	242	9 17/32"	See Standard	See Standard
E	79	3 1/8"	See Standard	See Standard	103	4 1/16"	See Standard	See Standard	103	4 1/16"	See Standard	See Standard	140	5 33/64"	See Standard	See Standard
F	460	1' 6 7/64"	731	2' 4 3/4"	461	1' 6 1/4"	775	2' 6 1/2"	442	1' 5 1/2"	808	2' 7 3/4"	442	1' 5 1/2"	808	2' 7 3/4"
G	96	3 25/32"	See Standard	See Standard	125	4 7/8"	See Standard	See Standard	126	4 61/64"	See Standard	See Standard	170	6 11/16"	See Standard	See Standard
H max	88	3 15/32"	359	1' 2 1/4"	110	4 21/64"	424	1' 4 3/4"	154	6 1/16"	520	1' 8 1/2"	154	6 1/16"	520	1' 8 1/2"
I	109	4 19/64"	See Standard	See Standard	142	5 19/32"	See Standard	See Standard	144	5 43/64"	See Standard	See Standard	196	7 3/4"	See Standard	See Standard
J	72	2 53/64"	See Standard	See Standard	72	2 53/64"	See Standard	See Standard	72	2 53/64"	See Standard	See Standard	72	2 53/64"	See Standard	See Standard
K	25	63/64"	See Standard	See Standard	33	1 1/4"	See Standard	See Standard	47	1 27/32"	See Standard	See Standard	47	1 27/32"	See Standard	See Standard
L	163	6 27/64"	434	1' 5 3/32"	181	7 1/4"	495	1' 7 1/2"	236	9 19/64"	601	1' 11 1/2"	236	9 19/64"	601	1' 11 1/2"
L1	18	45/64"	See Standard	See Standard	18	45/64"	See Standard	See Standard	20	25/32"	See Standard	See Standard	20	25/32"	See Standard	See Standard
M	68	2 43/64"	See Standard	See Standard	64	2 33/64"	See Standard	See Standard	75	2 15/16"	See Standard	See Standard	75	2 15/16"	See Standard	See Standard
N	15	19/32"	See Standard	See Standard	15	19/32"	See Standard	See Standard	17	43/64"	See Standard	See Standard	17	43/64"	See Standard	See Standard
O																
P	133	5 15/44"	See Standard	See Standard	157	6 3/16"	See Standard	See Standard	203	7	See Standard	See Standard	203	7 63/64"	See Standard	See Standard
Q	74	2 29/32"	See Standard	See Standard	88	3 15/32"	See Standard	See Standard	115	4 17/32"	See Standard	See Standard	115	4 17/32"	See Standard	See Standard
R	60	2 23/64"	See Standard	See Standard	66	2 19/32"	See Standard	See Standard	90	3 9/16"	See Standard	See Standard	90	3 9/16"	See Standard	See Standard
S																
T max	26	1 1/32"	See Standard	See Standard	32	1 17/64"	See Standard	See Standard	42	1 21/32"	See Standard	See Standard	42	1 21/32"	See Standard	See Standard
U	165	6 1/2"	See Standard	See Standard	199	7 53/64"	See Standard	See Standard	262	10 1/2"	See Standard	See Standard	262	10 1/2"	See Standard	See Standard
V	76	2 63/64"	See Standard	See Standard	92	3 5/8"	See Standard	See Standard	105	4 9/64"	See Standard	See Standard	105	4 9/64"	See Standard	See Standard
W	97	3 13/16"	See Standard	See Standard	97	3 13/16"	See Standard	See Standard	115	4 17/32"	See Standard	See Standard	115	4 17/32"	See Standard	See Standard
X			40	1 37/64"			52	2 1/16"			60	2 23/64"			60	2 23/64"
Y	25	63/64"	See Standard	See Standard	35	13/8"	See Standard	See Standard	42	1 21/32"	See Standard	See Standard	42	1 21/32"	See Standard	See Standard
Z	8127	26' 7 63/64"	8398	27' 6 1/2"	12160	39' 10 3/4"	12475	40' 11 1/4"	14230	46' 8 1/4"	14595	47' 10 5/8"	16230	53' 2"	16595	54' 5"
Short link plates																
a	50	(1 32/32")	50	(1 32/32")	50	(1 32/32")	50	(1 32/32")	55	(2 5/32")	55	(2 5/32")	55	(2 5/32")	55	(2 5/32")
f	15	(19/32")	15	(19/32")	15	(19/32")	15	(19/32")	20	(25/32")	20	(25/32")	20	(25/32")	20	(25/32")
Link plates																
a	340	1' 1 25/64"	180	7 3/32"	340	1' 1 25/64"	180	7 3/32"	500	1' 7 3/4"	200	7 7/8"	500	1' 7 3/4"	250	9 27/32"
b	305	1' 1/64"	145	5 7/8"	305	1' 1/64"	145	5 7/8"	465	1' 6 5/16"	165	6 3/4"	465	1' 6 5/16"	215	8 1/4"
c	270	10 5/8"	110	4 23/32"	270	10 5/8"	110	4 23/32"	430	1' 4 7/8"	130	5 1/2"	430	1' 4 7/8"	180	6 3/4"
d	235	9 1/4"	75	3 9/16"	235	9 1/4"	75	3 9/16"	395	1' 3 9/16"	95	4 5/16"	395	1' 3 9/16"	145	5 1/8"
e	4	5/32"	4	5/32"	4	5/32"	4	5/32"	4	5/32"	4	5/32"	4	5/32"	4	5/32"
f	16	19/32"	16	19/32"	16	19/32"	16	19/32"	16	19/32"	16	43/64"	16	19/32"	16	43/64"
g	41	1 39/64"	41	1 39/64"	41	1 39/64"	41	1 39/64"	41	1 39/64"	41	1 39/64"	61	2 9/16"	61	2 9/16"

	C480						R480						C520						C530					
	Standard			Turnbuckle cylinder			Standard			Turnbuckle cylinder			Standard			Turnbuckle cylinder			Standard			Turnbuckle cylinder		
	mm	inch		mm	inch		mm	inch		mm	inch		mm	inch		mm	inch		mm	inch		mm	inch	
A	68	2 43/64"		See standard	See standard		68	2 43/64"		See standard	See standard		68	2 43/64"		See standard	See standard		68	2 43/64"		See standard	See standard	
B	14	35/64"		See standard	See standard		14	35/64"		See standard	See standard		14	35/64"		See standard	See standard		14	35/64"		See standard	See standard	
C	28	1 7/64"		See standard	See standard		28	1 7/64"		See standard	See standard		28	1 7/64"		See standard	See standard		28	1 7/64"		See standard	See standard	
ØD	250	9 27/32"		See standard	See standard		250	9 27/32"		See standard	See standard		250	9 27/32"		See standard	See standard		250	9 27/32"		See standard	See standard	
ØD1	276	10 1 55/64"		See standard	See standard		276	10 1 55/64"		See standard	See standard		276	10 1 55/64"		See standard	See standard		276	10 1 55/64"		See standard	See standard	
E	146	5 3/4"		See standard	See standard		146	5 3/4"		See standard	See standard		146	5 3/4"		See standard	See standard		168	5 3/4"		See standard	See standard	
F	535	1 9 1/8"		See standard	See standard		535	1 9 1/8"		See standard	See standard		535	1 9 1/8"		See standard	See standard		535	1 9 1/8"		1062	3 5 13/16"	
G	170.5	6 11/16"		See standard	See standard		170	6 11/16"		See standard	See standard		170	6 11/16"		See standard	See standard		192.5	6 11/16"		See standard	See standard	
H max	205	8 5/64"		See standard	See standard		205	8 5/64"		See standard	See standard		205	8 5/64"		See standard	See standard		223	8 5/64"		748	2 4 47/64"	
I	194	7 41/64"		See standard	See standard		194	7 41/64"		See standard	See standard		194	7 41/64"		See standard	See standard		218	7 41/64"		See standard	See standard	
J	84	3 5/16"		See standard	See standard		84	3 5/16"		See standard	See standard		84	3 5/16"		See standard	See standard		84	3 5/16"		See standard	See standard	
K	47	1 27/32"		See standard	See standard		47	1 27/32"		See standard	See standard		47	1 27/32"		See standard	See standard		47	1 27/32"		See standard	See standard	
L	319	10 9/16"		See standard	See standard		319	10 9/16"		See standard	See standard		319	10 9/16"		See standard	See standard		337	10 9/16"		863	2 9 17/64"	
L1	27	1 1/8"		See standard	See standard		27	1 1/8"		See standard	See standard		27	1 1/8"		See standard	See standard		27	1 1/8"		See standard	See standard	
M	100	3 15/16"		See standard	See standard		100	3 15/16"		See standard	See standard		100	3 15/16"		See standard	See standard		100	3 15/16"		See standard	See standard	
N	23.5	29/32"		See standard	See standard		23.5	29/32"		See standard	See standard		21.5	27/32"		See standard	See standard		21.5	27/32"		See standard	See standard	
P	250	9 27/32"		See standard	See standard		250	9 27/32"		See standard	See standard		250	9 27/32"		See standard	See standard		268	9 27/32"		See standard	See standard	
Q	125	4 59/64"		See standard	See standard		125	4 59/64"		See standard	See standard		125	4 59/64"		See standard	See standard		125	4 59/64"		See standard	See standard	
R	101	3 31/32"		See standard	See standard		101	3 31/32"		See standard	See standard		101	3 31/32"		See standard	See standard		101	3 31/32"		See standard	See standard	
T max	52	2 3/64"		See standard	See standard		52	2 3/64"		See standard	See standard		52	2 3/64"		See standard	See standard		52	2 3/64"		See standard	See standard	
U	342	1 1 15/32"		See standard	See standard		342	1 1 15/32"		See standard	See standard		342	1 1 15/32"		See standard	See standard		360	1 1 15/32"		See standard	See standard	
ØV	116	4 9/16"		See standard	See standard		116	4 9/16"		See standard	See standard		116	4 9/16"		See standard	See standard		116	4 9/16"		See standard	See standard	
W	146	5 3/4"		See standard	See standard		146	5 3/4"		See standard	See standard		146	5 3/4"		See standard	See standard		146	5 3/4"		See standard	See standard	
X	-	2 7/8"		See standard	See standard		73	2 7/8"		See standard	See standard		73	2 7/8"		See standard	See standard		-	2 7/8"		73	2 7/8"	
Y	48	1 57/64"		See standard	See standard		48	1 57/64"		See standard	See standard		52	2 3/64"		See standard	See standard		52	2 3/64"		See standard	See standard	
Z	18287	59 11 5/16"		See standard	See standard		18287	59 11 5/16"		See standard	See standard		20287	66 6 11/16"		See standard	See standard		22305	73 2 5/32"		22830	74 10 13/16"	
Link plates																								
a1	325	10 51/64"	Medium	Long	Long	Medium	325	10 51/64"	Long	675	2 2 37/64"	Long	325	10 51/64"	Medium	675	2 2 37/64"	Long	325	10 51/64"	Medium	675	2 2 37/64"	Long
a2	275	10 53/64"	Medium	Long	Long	Medium	275	10 53/64"	Long	625	2 0 39/64"	Long	275	10 53/64"	Medium	625	2 0 39/64"	Long	275	10 53/64"	Medium	625	2 0 39/64"	Long
a3	225	8 55/64"	Medium	Long	Long	Medium	225	8 55/64"	Long	575	1 10 41/64"	Long	225	8 55/64"	Medium	575	1 10 41/64"	Long	225	8 55/64"	Medium	575	1 10 41/64"	Long
a4	175	6 57/64"	Medium	Long	Long	Medium	175	6 57/64"	Long	525	1 8 43/64"	Long	175	6 57/64"	Medium	525	1 8 43/64"	Long	175	6 57/64"	Medium	525	1 8 43/64"	Long
a5	125	4 59/64"	Medium	Long	Long	Medium	125	4 59/64"	Long	475	1 6 45/64"	Long	125	4 59/64"	Medium	475	1 6 45/64"	Long	125	4 59/64"	Medium	475	1 6 45/64"	Long
a6	425	1 4 47/64"	Medium	Long	Long	Medium	425	1 4 47/64"	Long	425	1 4 47/64"	Medium	425	1 4 47/64"	Medium	425	1 4 47/64"	Long	425	1 4 47/64"	Medium	425	1 4 47/64"	Long
e	6	15/64"	Medium	Long	Long	Medium	6	15/64"	Long	6	15/64"	Long	6	15/64"	Medium	6	15/64"	Long	6	15/64"	Medium	6	15/64"	Long
f	25	63/64"	Medium	Long	Long	Medium	25	63/64"	Long	25	63/64"	Long	25	63/64"	Medium	25	63/64"	Long	25	63/64"	Medium	25	63/64"	Long
g	64 or 81	2 33/64"	Medium	Long	Long	Medium	64 or 81	2 33/64"	Long	64 or 81	2 33/64"	Long	64 or 81	2 33/64"	Medium	64 or 81	2 33/64"	Long	64 or 81	2 33/64"	Medium	64 or 81	2 33/64"	Long
	81	or 3 3/16"	Medium	Long	Long	Medium	or 3 3/16"	Long	or 3 3/16"	or 3 3/16"	or 3 3/16"	or 3 3/16"	or 3 3/16"	or 3 3/16"	Medium	or 3 3/16"	or 3 3/16"	or 3 3/16"	or 3 3/16"	or 3 3/16"	Medium	or 3 3/16"	or 3 3/16"	Long

DIMENSIONS FOR C480, C520, C530 AND R480 MODELS

Standard fitting

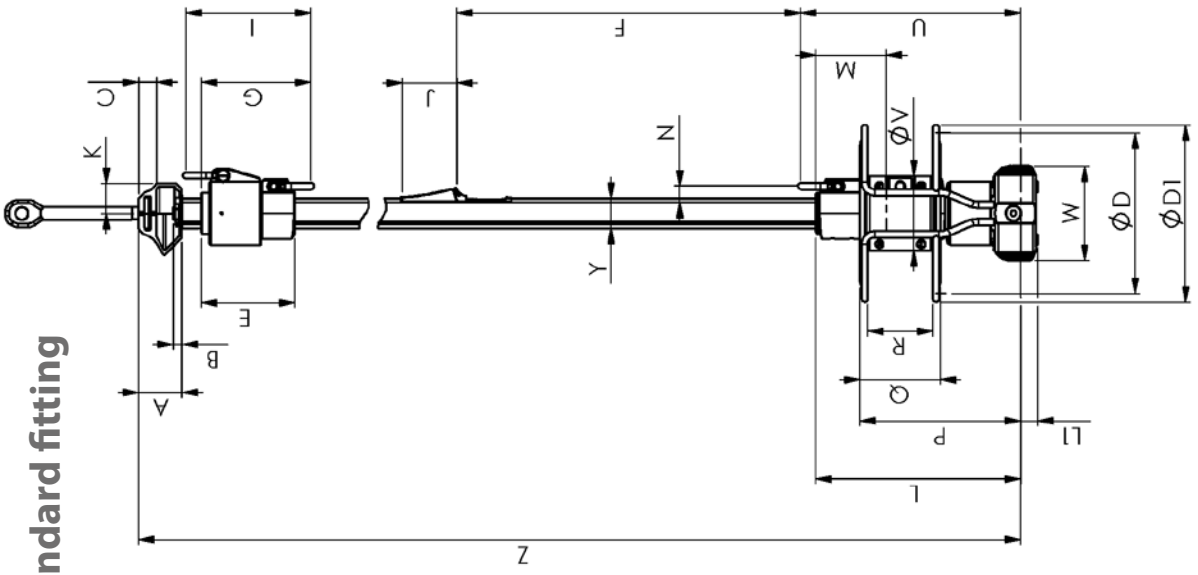

With turnbuckle cylinder

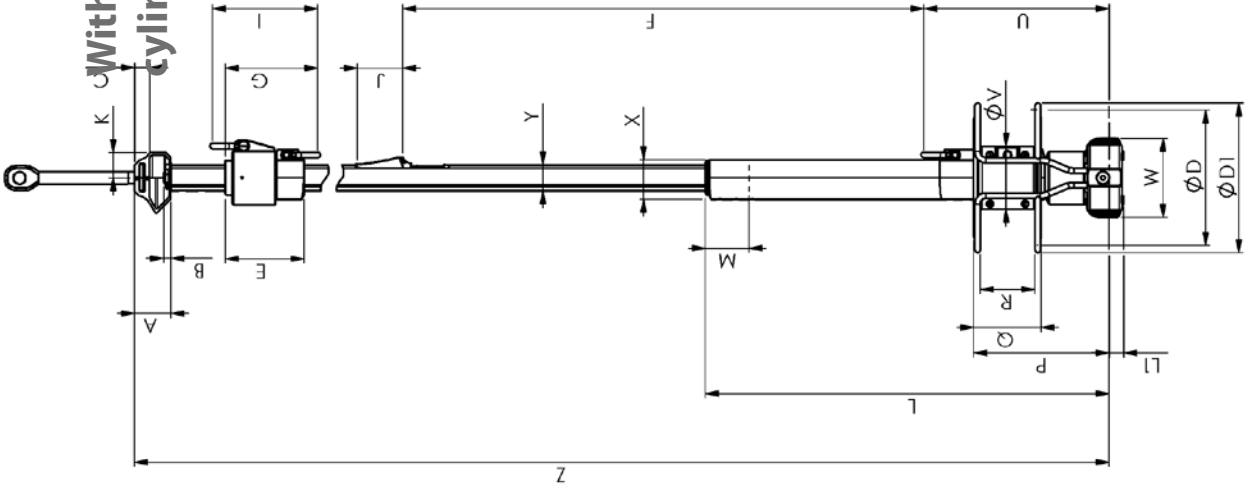

Long and medium link plates

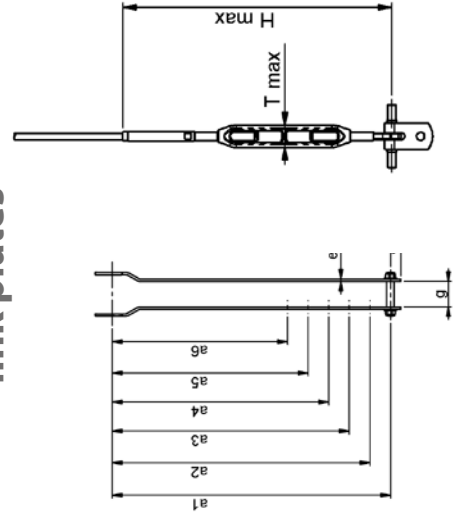

They sail with Profurl !



Pogo 44



Outremer 5.X
We Explore - Roland Jourdain



Victoire Martinet
Mini 6.50



Bureau Vallée 3 - L Burton
Imoca 60

UK Distributor

Proboat Ltd
Tel: +44 (0)1621-785455
email: sales@proboat.co.uk